



1.5 Tons Air Chain Hoist - Atex - Nickel kit

Key features

- 1.5 Ton Pneumatic Chain Hoist - Heavy Duty - Explosion Proof - Nickel Kit
- Additional Ex Protection Nickel Coated: Chain hook, bottom block, Sprocket, Load sleeve, Safety Catch
- Includes: Overload Protection - Slip Clutch / Failsafe Automatic Internal Break / Pendant Control with emergency stop / Chain containers / RUD G80 chain made in Germany (Lifting heights upon request)
- Meets and exceeds ASME B30.16 / HST-5 standards / Load Test at 130% SWL / ATEX Directive
- 3 Year Warranty, Customer Support and Service in the USA

1.5 Tons Air Chain Hoist - Atex - Nickel kit

Technical Specifications

Rated Load Capacity	1.5 Ton	Emergency Stop	Yes
Standard Lifting Height	20 ft / 6 m	Operating Temperature Range	-20°C to 70°C
Number of Speeds	1 Speed	Air Pressure	4 - 6 Bar
Air Hoist Lifting Speed at Rated Load	8.8 m/min	Air Inlet Size	3/4 BSP
Air Hoist Lifting Speed Unloaded	13.6 m/min	Air hose dimension	19mm - 25mm (3/4" - 1")
Capacity Range	3	Air Consumption	1.75 m3/min
Air Hoist Lowering Speed at Rated Load	13 m/min	Transmission / Reducer Type	Epicycle Gearbox (Grease Filled and Sealed)
Maximum Safe Overload	Overload Protection Slip Clutch 130% WLL	Load Chain Type	G80 RUG Germany 5:1 Safety Factor
Explosion Proof Protection	- EX 2 GD IIA T4 EX 2 GD IIB T4 EX 2 GD IIC T4 ZONES 1, 2 AND 21, 22 - Nickel Coated: Chain hook, bottom block, Sprocket, Load sleeve, Safety Catch	Load Chain Size	9 x 27 mm
Protection Exclusions	- HYDROGEN DISULPHIDE - ETHELENE OXIDE	Chain Falls	1
Control Distance	16 ft / 5 m	Temperature	-20°C to 70°C
Duty Class	100% Duty Cycle	Noise Level	83 dBA @ 1m
Motor/Engine Type	Vane Rotary Motor - Lubrication Free - Rust Free & Replaceable Stainless Steel Cylinder	Accessories	Spark Resistan (Atex Zone 1) Included
Motor/Engine Power	1.4 kw	Standards Compliance	ASME B30.11 /B30.16 /HST-5 DIN EN818-7 SANS 1638 compliant ATEX EX Classification according to EC Directive on Hazardous Locations 94/9/EEC
Motor Brake	>125% WLL Automatic self-adjusting multidisc Brake	Made in	South Africa
Control	Pendant Control w/emergency stop	Warranty	3 Year

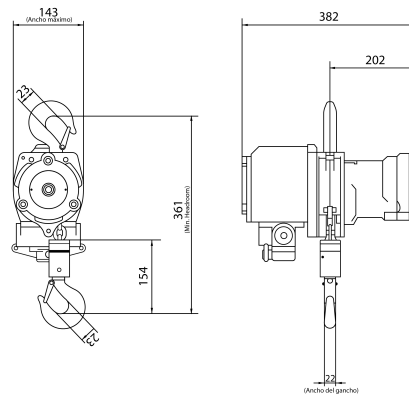

Dimensions in mm / Dimensiones en mm

Unit Weight & Dimensions

H Minimum Headroom	361 mm
W Width	384 mm
D Depth	143 mm
J Hook Opening	25 mm