



500 lb 1 Speed Electric Chain Hoist 20ft G100 Chain M4/H3 208~240/440~480V UL Wireless

Key features

- Capacity: 500 lbs lifting capacity
- Voltage Options: Compatible with 208~240/440~480V power supply
- Wireless Control: Equipped with a wireless remote for convenient operation
- 3 Year Warranty, Customer Support and Service in the USA

Electric Chain Hoist Description

The **Prowinch 1/4 ton Electric Chain Hoist** allows you to easily lift loads. The powerful motor and single phase electrical connection are perfect for use in a wide variety of situations and environments. The integrated wireless control offers added convenience with the ability to operate the hoist from up to 100 feet away.

Electric Chain Hoist Description

The Prowinch 1/4 ton Electric Chain Hoist allows you to easily lift loads. The powerful motor and single phase electrical connection are perfect for use in a wide variety of situations and environments. The integrated wireless control offers added convenience with the ability to operate the hoist from up to 100 feet away.

UL Certified Electric Chain Hoist

All of our Electric Chain Hoists are created with the goal of offering the best price-performance ratio. Key components such as lifespan factors are constantly tested and improved in order to offer the best product for the price.

Key Components

All internal components have been upgraded to meet the highest quality standards. Key electronic components are produced by American or German brands, and we use American-made lubricants to ensure the lifespan of gears and reducers. Final assembly and all tests are performed in the US before shipping to ensure that every unit meets the corresponding standard.

Duty Classification

Duty classification is a key factor when choosing the right unit. These H3 hoists are suitable for general machine shop fabricating, assembly, storage, and warehousing. For uniformly distributed work periods, the hoists have 25% max. operational time per hour and can handle up to 150 starts per hour. When being used for infrequent work periods, the hoist can be operated for 30 minutes from a cold start with up to 200 starts per hour. Operational time ratings are calculated at a 65% load factor, as per ASME HST-1-2012.

Control System

This Electric Chain Hoist comes with a pendant control with up, down, and emergency stop. The length of the pendant control is 4 feet less than the lifting height, which allows it to be easily operated from ground-level.

Braking System

The electromagnetic brake system is tested at 125% of the hoist capacity and is designed to automatically engage immediately upon any loss of power.

Technical Specifications

Rated Load Capacity	500 lb	Control	Wireless and Pendant Control
Standard Lifting Height	20 ft / 6 m	Control Voltage	24V
Speed (f/m) / min	26ft/ 8m	Emergency Stop	Yes
Number of Speeds	1 Speed	Load Chain Type	G100
Voltage	3 Phase 208~240/440~480V 50/60Hz	Load Chain Size	5x15 mm
Available Voltages	208~240/440~480V for USA and 380/440~480V for CHILE	Chain Falls	1
FCC ID	2AZMK-Q1212	Chain Length	20 ft / 6 m
Duty Class	H3/M4/1Am/Class C	Humidity	<85%
Motor Power (6)	0.4 kW	Temperature	-4 ~ 104° F / -20 ~ 40° C
Motor Brake	Yes DC Electromagnetic	Noise Level	81 dB
Insulation Grade	F	Standards Compliance	UL 1340 - ASME HST-1 , ASME B30.16 , EN60204-32
IEC Motor Protection	IP55	Warranty	3 Year

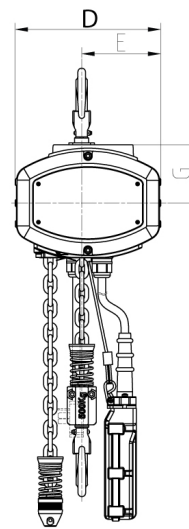
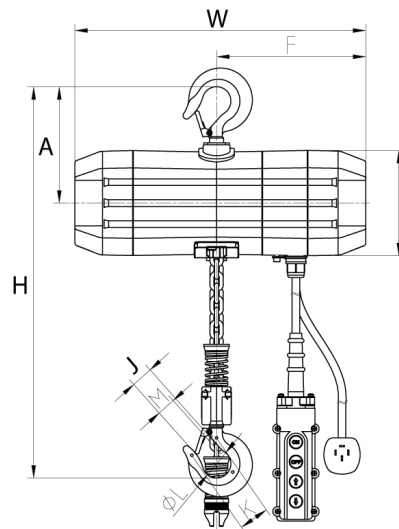

Unit Weight & Dimensions

Total Unit Weight	120 lbs / 55 Kg
--------------------------	-----------------

Packaging Weight & Dimensions

Package 1 Net Weight	120 lbs / 54 Kg
Package 1 Width	19 in / 48.26 cm
Package 1 Gross Weight	123 lbs / 56 Kg
Package 1 Height	18 in / 45.72 cm
Package 1 Length	24 in / 60.96 cm