



## 2000 lb 1 Speed Wireless Electric Chain Hoist 115/230V 20 ft G100 Chain UL Certified

### Key features

- Capacity: Lifts up to 2000 lbs
- Power Supply: Dual voltage (115/230V) for versatile use
- Speed: Single-speed operation for efficient lifting
- 3 Year Warranty, Customer Support and Service in the USA

### Electric Chain Hoist Description

The Prowinch 1 ton Electric Chain Hoist allows you to easily lift loads. The powerful motor and single phase electrical connection are perfect for use in a wide variety of situations and environments. The integrated wireless control offers added convenience with the ability to operate the hoist from up to 100 feet away.

### UL Certified Electric Chain Hoist

All of our **Electric Chain Hoists** are created with the goal of offering the best price-performance ratio. Key components such as lifespan factors are constantly tested and improved in order to offer the best product for the price.

### Key Components

All internal components have been upgraded to meet the highest quality standards. Key electronic components are produced by American or German brands, and we use American-made lubricants to ensure the lifespan of gears and reducers. Final assembly and all tests are performed in the US before shipping to ensure that every unit meets the corresponding standard.

### Duty Classification

Duty classification is a key factor when choosing the right unit. These H3 hoists are suitable for general machine shop fabricating, assembly, storage, and warehousing. For uniformly distributed work periods, the hoists have 25% max. operational time per hour and can handle up to 150 starts per hour. When being used for infrequent work periods, the hoist can be operated for 30 minutes from a cold start with up to 200 starts per hour. Operational time ratings are calculated at a 65% load factor, as per ASME HST-1-2012.

### Control System

This **Electric Chain Hoist** comes with a pendant control with up, down, and emergency stop. The length of the pendant control is 4 feet less than the lifting height, which allows it to be easily operated from ground-level.

### Braking System

The **electromagnetic brake system** is tested at 125% of the hoist capacity and is designed to automatically engage immediately upon any loss of power.

## Technical Specifications

<b>Rated Load Capacity</b>	2000 lbs	<b>Control</b>	Pendant Control and Industrial Wireless Control
<b>Standard Lifting Height</b>	20 ft / 6 m	<b>Control Voltage</b>	24V
<b>Speed (f/m) / min</b>	16 ft / 5.0 m	<b>Emergency Stop</b>	Yes
<b>Number of Speeds</b>	1 Speed	<b>Load Chain Type</b>	G100
<b>Voltage</b>	1 Phase 110~120/220~240V 50/60Hz	<b>Load Chain Size</b>	8x24 mm
<b>Total Power Watts</b>	1000	<b>Chain Falls</b>	1
<b>FCC ID</b>	2AZMK-Q1212	<b>Chain Length</b>	20 ft / 6 m
<b>Duty Class</b>	H3/M4/1Am/Class C	<b>Humidity</b>	<85%
<b>Motor Power (6)</b>	1.3 kW	<b>Temperature</b>	-4 ~ 104° F / -20 ~ 40° C
<b>Motor Brake</b>	Yes DC Electromagnetic	<b>Noise Level</b>	81 dB
<b>Insulation Grade</b>	F	<b>Standards Compliance</b>	UL 1340, ASME HST-1, ASME B30.16, B30.17, EN60204-32
<b>IEC Motor Protection</b>	IP55	<b>Warranty</b>	3 Year

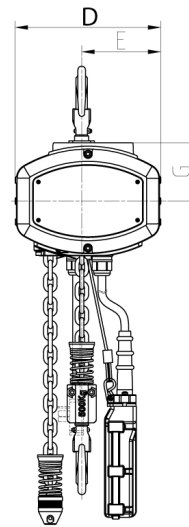
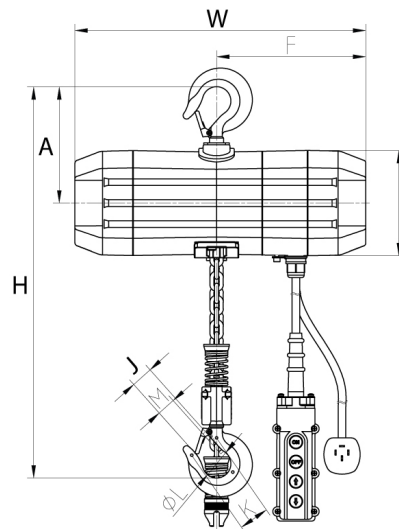

## Unit Weight & Dimensions

<b>H Minimum Headroom</b>	21.5 in	<b>Package 1 Net Weight</b>	149 lbs / 68 Kg
<b>W Width</b>	19.4 in	<b>Package 1 Width</b>	22 in / 55.88 cm
<b>D Depth</b>	11.6 in	<b>Package 1 Gross Weight</b>	155 lbs / 70 Kg
<b>J Hook Opening</b>	1.4 in	<b>Package 1 Height</b>	20 in / 50.8 cm
<b>Total Unit Weight</b>	149 lbs / 68 Kg	<b>Package 1 Length</b>	25 in / 63.5 cm

## Packaging Weight & Dimensions