



1000 lb 1 Speed Wireless Electric Chain Hoist 115/230V 20 ft G100 Chain UL Certified

Key features

- Capacity: Lifts up to 1000 lbs
- Power Supply: Dual voltage capability (115/230V)
- Speed: Single-speed operation for straightforward lifting
- 3 Year Warranty, Customer Support and Service in the USA

Electric Chain Hoist Description

The Prowinch 1/2 ton Electric Chain Hoist allows you to easily lift loads. The powerful motor and single phase electrical connection are perfect for use in a wide variety of situations and environments. The integrated wireless control offers added convenience with the ability to operate the hoist from up to 100 feet away.

UL Certified Electric Chain Hoist

All of our **Electric Chain Hoists** are created with the goal of offering the best price-performance ratio. Key components such as lifespan factors are constantly tested and improved in order to offer the best product for the price.

Key Components

All internal components have been upgraded to meet the highest quality standards. Key electronic components are produced by American or German brands, and we use American-made lubricants to ensure the lifespan of gears and reducers. Final assembly and all tests are performed in the US before shipping to ensure that every unit meets the corresponding standard.

Duty Classification

Duty classification is a key factor when choosing the right unit. These H3 hoists are suitable for general machine shop fabricating, assembly, storage, and warehousing. For uniformly distributed work periods, the hoists have 25% max. operational time per hour and can handle up to 150 starts per hour. When being used for infrequent work periods, the hoist can be operated for 30 minutes from a cold start with up to 200 starts per hour. Operational time ratings are calculated at a 65% load factor, as per ASME HST-1-2012.

Control System

This **Electric Chain Hoist** comes with a pendant control with up, down, and emergency stop. The length of the pendant control is 4 feet less than the lifting height, which allows it to be easily operated from ground-level.

Braking System

The **electromagnetic brake system** is tested at 125% of the hoist capacity and is designed to automatically engage immediately upon any loss of power.

Technical Specifications

Rated Load Capacity	1000 lbs	Control	Pendant Control and Industrial Wireless Control
Standard Lifting Height	20 ft / 6 m	Control Voltage	24V
Speed (f/m) / min	16 ft / 5.0 m	Emergency Stop	Yes
Number of Speeds	1 Speed	Load Chain Type	G100
Voltage	1 Phase 110~120/220~240V 50/60Hz	Load Chain Size	6.3x19mm
Total Power Watts	500	Chain Falls	1
FCC ID	2AZMK-Q1212	Chain Length	20 ft / 6 m
Duty Class	H3/M4/1Am/Class C	Humidity	<85%
Motor Power (6)	0.65 kW	Temperature	-4 ~ 104° F / -20 ~ 40° C
Motor Brake	Yes DC Electromagnetic	Noise Level	81 dB
Insulation Grade	F	Standards Compliance	UL 1340, ASME HST-1, ASME B30.16, B30.17, EN60204-32
IEC Motor Protection	IP55	Warranty	3 Year

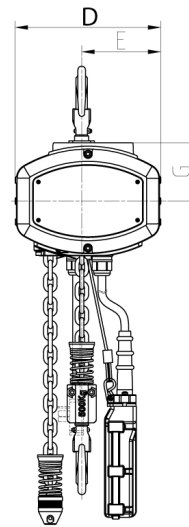
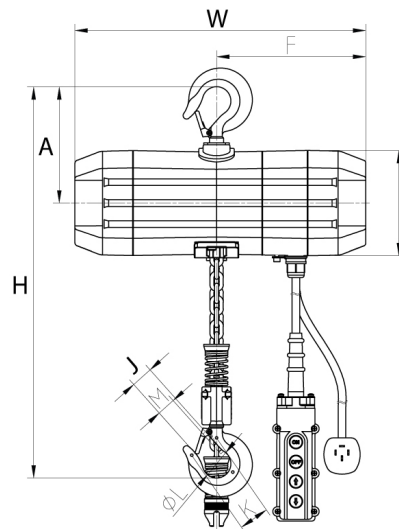

Unit Weight & Dimensions

H Minimum Headroom	17.9 in	Package 1 Net Weight	99 lbs / 45 Kg
W Width	18.6 in	Package 1 Width	19 in / 48.26 cm
D Depth	9 in	Package 1 Gross Weight	124 lbs / 56 Kg
J Hook Opening	1.2 in	Package 1 Height	18 in / 45.72 cm
Total Unit Weight	99 lbs / 45 Kg	Package 1 Length	24 in / 60.96 cm

Packaging Weight & Dimensions