

20 Tons Air Chain Hoist with Trolley - Explosion Proof

Key features

- 3 Year Warranty, Customer Support and Service in the USA

20 Tons Air Chain Hoist with Trolley - Explosion Proof

Technical Specifications

Rated Load Capacity	20 Ton	Air Inlet Size	3/4" BSP
Standard Lifting Height	50 ft / 15 m	Air hose dimension	19 - 25 mm (3/4 - 1 ")
Number of Speeds	1 Speed	Air Consumption	110 cfm / 3.12 m3/min
Air Hoist Lifting Speed at Rated Load	0.65 m/min	Transmission / Reducer Type	Epicycle Gearbox (Grease Filled and Seald)
Air Hoist Lifting Speed Unloaded	1.4 m/min	Load Chain Type	G80 RUG Germany 5:1 Safety Factor
Capacity Range	9	Load Chain Size	16 x 45 mm
Air Hoist Lowering Speed at Rated Load	1.8 m/min	Chain Falls	4
Maximum Safe Overload	Overload Protection Slip Clutch 130% WLL	Chain Length	56 m
Explosion Proof Protection	EX 2 GD IIA T4 EX 2 GD IIB T4 EX 2 GD IIC T4 ZONES 1, 2 AND 21, 22 - Copper Coated: Chain hook, bottom block, Sprocket, Load sleeve, Safety Catch - Stainless Steel Wheels	Trolley Power	0.9 kW
Protection Exclusions	- HYDROGEN DISULPHIDE - ETHELENE OXIDE	Noise Level	84 dBA @ 1m
Duty Class	100% Duty Cycle	Trolley Speed /min	12 m/min
Motor/Engine Type	Vane Rotary Motor - Lubrication Free - Rust Free & Replaceable Stainless Steel Cylinder	Trolley Number of Speeds	1
Motor/Engine Power	3.2 kw	I-Beam Width Range	175 - 330 mm
Motor Brake	>125% WLL Automatic self-adjusting multidisc Brake	Minimum Turn Radius	3.5 m
Control	Pendant Control 4 buttons w/emergency stop	Standards Compliance	ASME B30.11 / B30.16 / B30.17 / HST-5 DIN EN818-7 SANS 1638 compliant ATEX EX Classification according to EC Directive on Hazardous Locations 94/9/EEC
Emergency Stop	Yes, on pendant Control	Made in	Southafrica
Operating Temperature Range	-20°C to 70°C	Warranty	3 Year
Air Pressure	4.5-7 Bar		

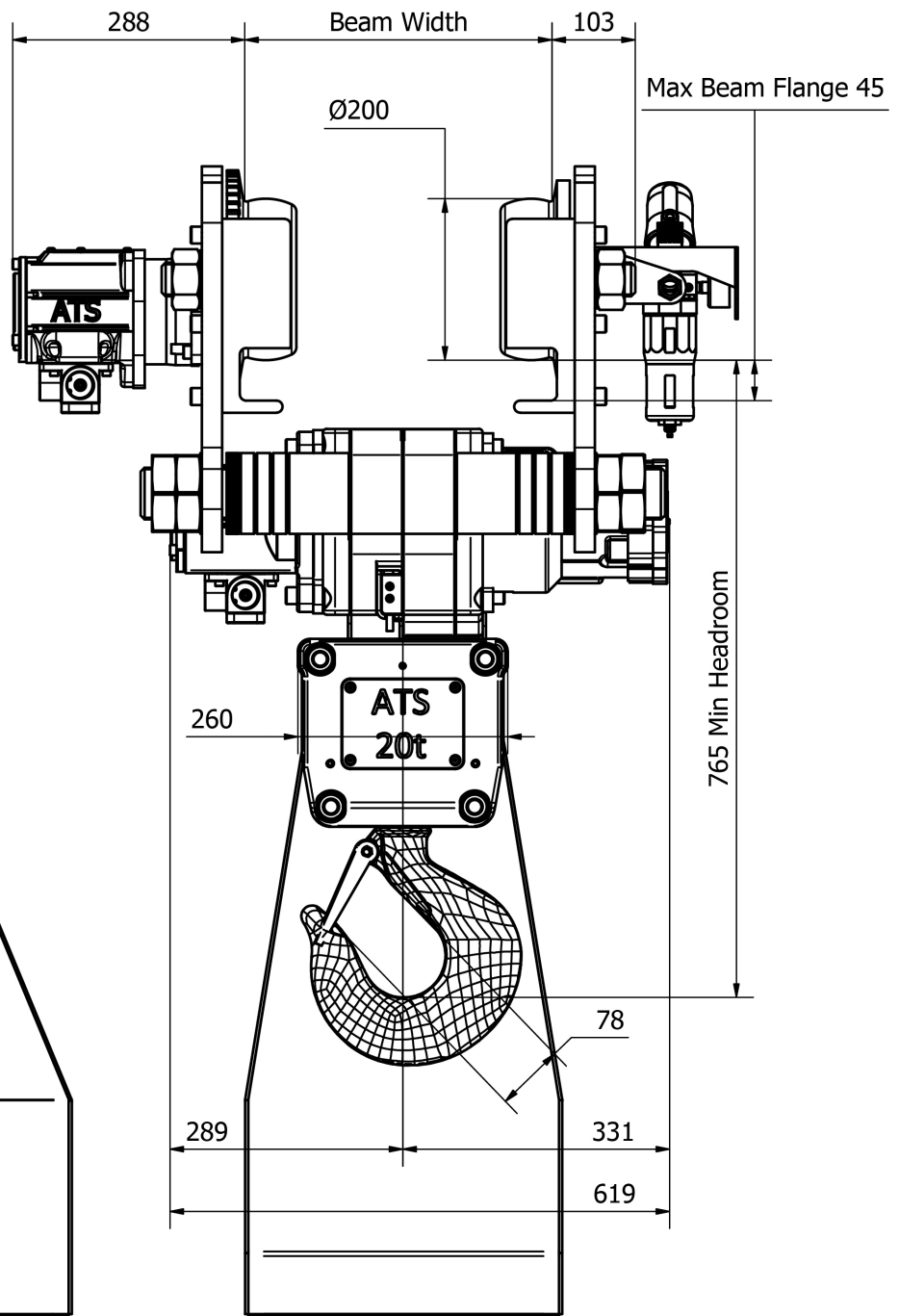
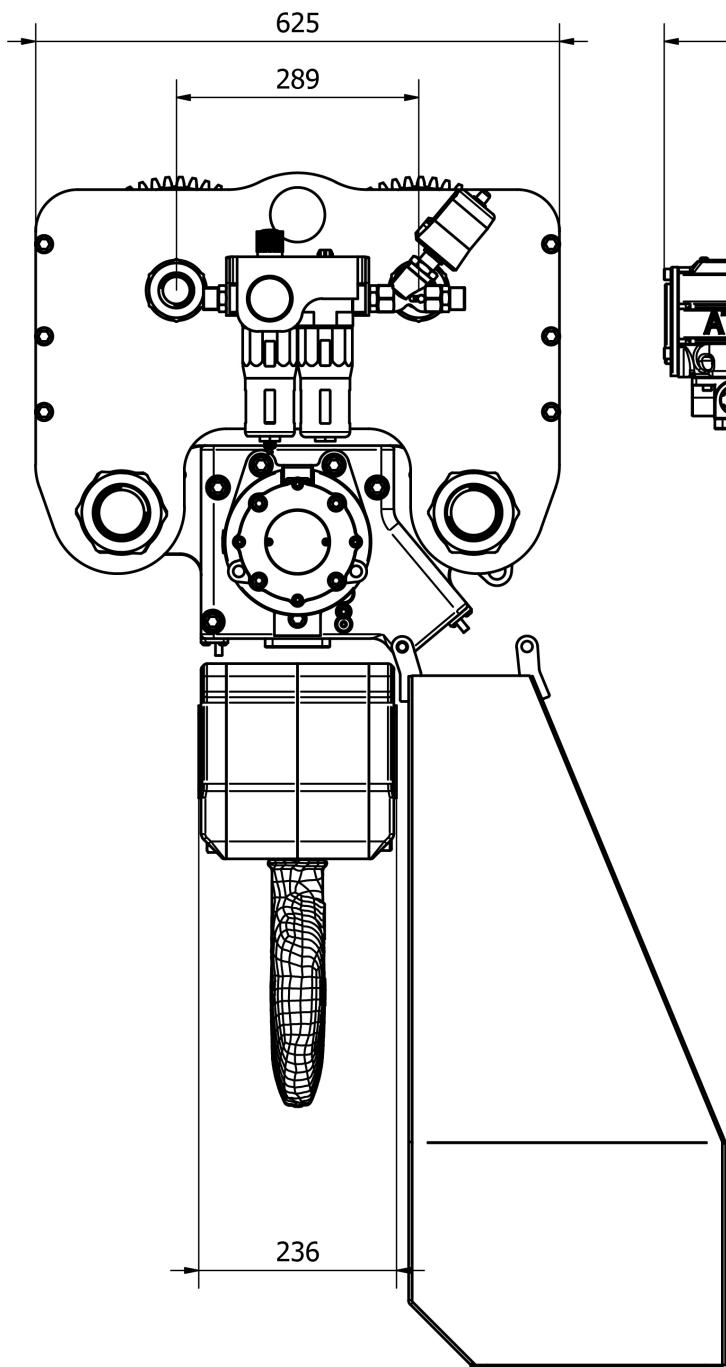

Chain bin to change subject to quantity of chain specified

Unit Weight & Dimensions

T Trolley Motor Width 288 mm

Packaging Weight & Dimensions

Package 1 Net Weight 1655 lbs / 751 Kg

W Width	391 mm Beam width	Package 1 Gross Weight	1755 lbs / 796 Kg
H Minimum Headroom	750 mm		
J Hook Opening	78 mm		
D Depth	625 mm		
Total Weight (w/out cable or Chain)	750 kg		
Total Unit Weight	1655 lbs / 751 Kg		