



7 Ton Electric Chain Hoist Power Trolley 1 Speed 30 ft. G100 Chain M4/H3 220~240/380/460V

Key features

- Load Capacity: Handles up to 7 tons (15,400 lbs.), designed for heavy-duty lifting applications.
- Speed: Features a single-speed operation for reliable and steady lifting performance.
- Power Trolley: Includes a power trolley for smooth and efficient horizontal movement along the beam.
- 3 Year Warranty, Customer Support and Service in the USA

Electric Chain Hoist Description

This **7 ton Electric Chain Hoist with Power Trolley** uses a powerful motor to raise and lower loads up to 30 feet in the air. The three-phase power supply makes it ideal for industrial applications. The hoist is easy to use, and the convenient trolley helps you complete large projects with ease.

Prowinch Electric Chain Hoist

All of our Electric Chain Hoists are created with the goal of offering the best price-performance ratio. Key components such as lifespan factors are constantly tested and improved in order to offer the best product for the price. We offer optional variable speed trolleys with a potentiometer for those customers moving sensitive loads.

Key Components

All internal components have been upgraded to meet the highest quality standards. Key electronic components are produced by American or German brands, and we use American-made lubricants to ensure the lifespan of gears and reducers. Final assembly and all tests are performed in the US before shipping to ensure that every unit meets the corresponding standard.

Duty Classification

Duty classification is a key factor when choosing the right unit. These H3 hoists are suitable for general machine shop fabricating, assembly, storage, and warehousing. For uniformly distributed work periods, the hoists have 25% max. operational time per hour and can handle up to 150 starts per hour. When being used for infrequent work periods, the hoist can be operated for 30 minutes from a cold start with up to 200 starts per hour. Operational time ratings are calculated at a 65% load factor, as per ASME HST-1-2012.

Control System

This electric chain hoist comes standard with a pendant control. The length of the control is 4 feet less than the lifting height, which allows it to be easily operated from ground-level. An optional wireless control is available for extra convenience.

Braking System

The electromagnetic brake system is tested at 125% of the hoist capacity and is designed to automatically engage immediately upon any loss of power.

Technical Specifications

Rated Load Capacity	16530 lb / 7500kg	Contactors	EATON 25 AMP
Standard Lifting Height	30 ft / 9 m	Transmission / Reducer Type	Spur gearbox with Oil splash lubrication
Speed (f/m) / min	7.2ft/2m@60Hz 6 ft / 1.8m@50Hz	Load Chain Type	G100
Number of Speeds	1 Speed	Load Chain Size	11.2 x 34 mm
Voltage	3 Phase 208~240/440~480V 50/60Hz	Chain Falls	3
USA and Canada Voltage	208~240/440~480V	Chain Length	90 ft / 27 m
Available Voltages	208~240/440~480V for USA and 380/440~480V for CHILE	Humidity	<85%
Duty Class	H3/M4/1Am/Class C	Temperature	-4 ~ 104° F / -20 ~ 40° C
Motor Power (6)	3 kW	Trolley Power	0.8 kW
Motor AMP	10 / 5	Noise Level	81 dB
Motor RPM	1728@60Hz 1440@50HZ	Trolley Speed /min	36 ft / 11 m
Motor Brake	Yes	Trolley Number of Speeds	1
Insulation Grade	F	I-Beam Width Range	100-178 mm
IEC Motor Protection	IP55	Minimum Turn Radius	5.9 ft / 1.8 m
Control	Pendant Control and Optional Wireless	Standards Compliance	ASME HST-1 , ASME B30.16 , B30.17 , EN60204-32
Control Voltage	24V	Warranty	3 Year
Emergency Stop	Yes		

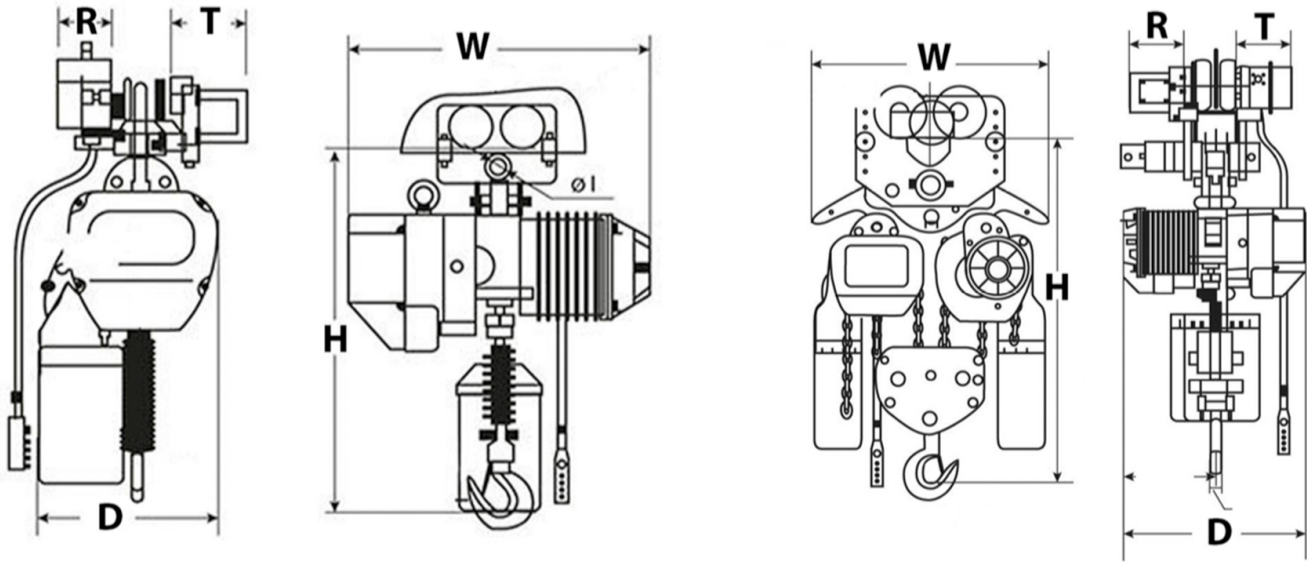

Dimensions

Model		PWRC1	PWRC2	PWRC3	PWRC5	PWRC7	PWRC10	PWRC20
T	in	9.09	9.09	9.09	9.09	9.09	9.09	9.09
H		25.5	30.5	33	40	48	55	58
W		20.5	24.5	24	24	24	25	25
R		5.5	5.5	5.5	5.5	5.5	5.5	5.5
D		12	17	17	17	20	35	50



Unit Weight & Dimensions

Packaging Weight & Dimensions

T Trolley Motor Width	9.09 in / 231 mm	Package 1 Net Weight	495 lbs / 225 Kg
D Depth	15 in / 380 mm	Package 1 Width	23 in / 58.42 cm
R Trolley Cover Width	5.5 in / 142 mm	Package 1 Gross Weight	539 lbs / 245 Kg
W Width	24 in / 615 mm	Package 1 Height	35 in / 88.9 cm
H Minimum Headroom	48 in / 1200 mm	Package 1 Length	27 in / 68.58 cm
J Hook Opening	70		
Total Unit Weight	495 lbs / 225 Kg		