



5 Ton Electric Chain Hoist Power Trolley 1 Speed 30 ft. FEC G80 Japan Chain M5/H4 208V/240V/480V

Key features

- Load Capacity: 5 tons (11,000 lbs), designed for heavy-duty industrial lifting.
- Speed: Single-speed operation ensures stable and consistent lifting performance.
- Power Trolley: Powered trolley for smooth and efficient horizontal movement along beams.
- 3 Year Warranty, Customer Support and Service in the USA

Electric Chain Hoist Description

This **5 ton Electric Chain Hoist with Power Trolley** uses a powerful motor to raise and lower loads up to 30 feet in the air. The three-phase power supply and M5 duty cycle make it ideal for industrial applications. The hoist is easy to use, and the convenient trolley helps you complete even the largest projects with ease.

Prowinch Electric Chain Hoist with Power Trolley

All of our Electric Chain Hoists are created with the goal of offering the best price-performance ratio. Key components such as lifespan factors are constantly tested and improved in order to offer the best product for the price.

Key Components

All internal components have been upgraded to meet the highest quality standards. Key electronic components are produced by American or German brands, and we use American-made lubricants to ensure the lifespan of gears and reducers. Final assembly and all tests are performed in the US before shipping to ensure that every unit meets the corresponding standard.

Duty Classification

Duty Classification is a key factor when choosing the right unit. These H4 hoists are suitable for high-volume handling in steel warehouses, machine shops, fabricating plants and mills, and foundries. For uniformly distributed work periods, the hoists have 50% max. operational time per hour and can handle up to 300 starts per hour. When being used for infrequent work periods, the hoist can be operated for 30 minutes from a cold start with up to 300 starts per hour. Operational time ratings are calculated at a 65% load factor, as per ASME HST-1-2012.

Control System

This electric chain hoist comes standard with a pendant control. The length of the control is 4 feet less than the lifting height, which allows it to be easily operated from ground-level. An optional wireless control is available for extra convenience.

Braking System

The electromagnetic brake system is tested at 125% of the hoist capacity and is designed to automatically engage immediately upon any loss of power.

Technical Specifications

Rated Load Capacity	11000 lb / 5000kg	Emergency Stop	Yes
Standard Lifting Height	30 ft / 9 m	Contactors	Schneider 25 AMP
Speed (f/m) / min	13ft/4m@60Hz 10.9/3.3m@50Hz	Transmission / Reducer Type	Spur gearbox with Oil splash lubrication
Number of Speeds	1 Speed - Optional Variable Speed	Load Chain Type	G80 JAPAN
Voltage	3 Phase 208~240/440~480V 50/60Hz	Load Chain Size	11.2 x 34 mm
USA and Canada Voltage	208~240/440~480V	Chain Falls	2
Available Voltages	208~240/440~480V for USA and 380/440~480V for CHILE	Chain Length	60 ft / 18 m
Duty Class	H4/M5/2m/Class D	Humidity	<85%
Motor Power (6)	3 kW	Temperature	-4 ~ 104° F / -20 ~ 40° C
Motor AMP	10 / 5	Trolley Power	0.8 kW
Motor RPM	1728@60Hz 1440@50HZ	Noise Level	81 dB
Motor Brake	Yes DC Electromagnetic	Trolley Speed /min	36 ft / 11 m (Opt. kit 69 ft / 21m)
Insulation Grade	F	Trolley Number of Speeds	1
IEC Motor Protection	IP55	I-Beam Width Range	58-153 mm
Dynamic Brake	Only with Optional VFD	Minimum Turn Radius	4.9 ft / 1.5 m
Control	Pendant Control and Optional Wireless	Standards Compliance	ASME HST-1 , ASME B30.16 , B30.17 , EN60204-32
Control Voltage	24V	Warranty	3 Year

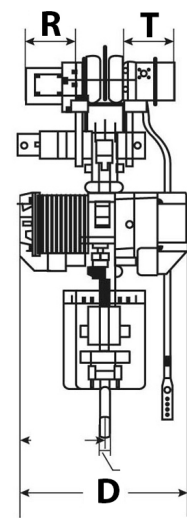
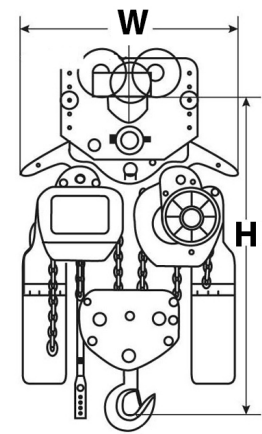
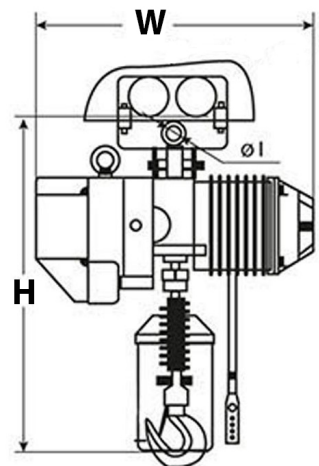
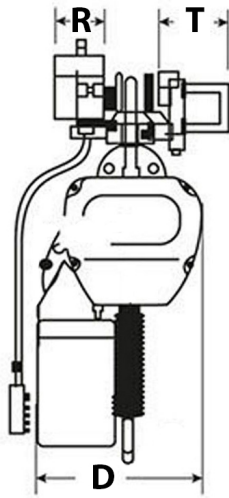

Unit Weight & Dimensions

T Trolley Motor Width	6.14 in / 156 mm
D Depth	22 in / 545 mm
R Trolley Cover Width	8 in / 200 mm
W Width	30 in / 745 mm
H Minimum Headroom	34 in / 865 mm
J Hook Opening	1.9 in / 48 mm
Total Unit Weight	538 lbs / 245 Kg

Packaging Weight & Dimensions

Package 1 Net Weight	538 lbs / 244 Kg
Package 1 Width	16 in / 40.64 cm
Package 1 Gross Weight	590 lbs / 268 Kg
Package 1 Height	45 in / 114.3 cm
Package 1 Length	34 in / 86.36 cm