



## 2 Ton Electric Chain Hoist Power Trolley 1 Speed 20 ft. FEC G80 Japan Chain M5/H4 220v/460v

### Key features

- Load Capacity: Supports up to 2 tons (4,400 lbs.), suitable for medium to heavy-duty lifting applications.
- Speed: Operates with a single speed for reliable and consistent lifting performance.
- Power Trolley: Includes a power trolley for smooth and efficient horizontal movement along the beam.
- 3 Year Warranty, Customer Support and Service in the USA

### Electric Chain Hoist Description

This 20 ft 2 ton Electric Chain Hoist with Power Trolley can be mounted wherever you need it. The hoist has a 20 foot lifting height and raises and lowers heavy loads with a powerful M5 duty cycle motor. The three-phase power supply and quick-connect electrical wiring system make it ideal for industrial or home applications.

### Prowinch Electric Chain Hoist with Power Trolley

All of our Electric Chain Hoists are created with the goal of offering the best price-performance ratio. Key components such as lifespan factors are constantly tested and improved in order to offer the best product for the price.

### Key Components

All internal components have been upgraded to meet the highest quality standards. Key electronic components are produced by American or German brands, and we use American-made lubricants to ensure the lifespan of gears and reducers. Final assembly and all tests are performed in the US before shipping to ensure that every unit meets the corresponding standard.

### Duty Classification

Duty Classification is a key factor when choosing the right unit. These H4 hoists are suitable for high-volume handling in steel warehouses, machine shops, fabricating plants and mills, and foundries. For uniformly distributed work periods, the hoists have 50% max. operational time per hour and can handle up to 300 starts per hour. When being used for infrequent work periods, the hoist can be operated for 30 minutes from a cold start with up to 300 starts per hour. Operational time ratings are calculated at a 65% load factor, as per ASME HST-1-2012.

### Control System

This electric chain hoist comes standard with a pendant control. The length of the control is 4 feet less than the lifting height, which allows it to be easily operated from ground-level. An optional wireless control is available for extra convenience.

### Braking System

The electromagnetic brake system is tested at 125% of the hoist capacity and is designed to automatically engage immediately upon any loss of power.

## Technical Specifications

<b>Rated Load Capacity</b>	4400 lb / 2000 kg	<b>Emergency Stop</b>	Yes
<b>Standard Lifting Height</b>	20 ft / 6 m	<b>Contactors</b>	EATON 25 AMP
<b>Speed (f/m) / min</b>	27.5ft/8.2m@60Hz 23ft/6.9m@50Hz	<b>Transmission / Reducer Type</b>	Spur gearbox with Oil splash lubrication
<b>Number of Speeds</b>	1 Speed - Optional Variable Speed	<b>Load Chain Type</b>	G80 JAPAN
<b>Voltage</b>	3 Phase 208~240/440~480V 50/60Hz	<b>Load Chain Size</b>	10 x 30 mm
<b>USA and Canada Voltage</b>	208~240/440~480V	<b>Chain Falls</b>	1
<b>Available Voltages</b>	208~240/440~480V for USA and 380/440~480V for CHILE	<b>Chain Length</b>	30 ft / 9 m
<b>Duty Class</b>	H4/M5/2m/Class D	<b>Humidity</b>	<85%
<b>Motor Power (6)</b>	3 kW	<b>Temperature</b>	-4 ~ 104° F / -20 ~ 40° C
<b>Motor AMP</b>	10 / 5	<b>Trolley Power</b>	0.4 kW
<b>Motor RPM</b>	1728@60Hz 1440@50HZ	<b>Noise Level</b>	81 dB
<b>Motor Brake</b>	Yes DC Electromagnetic	<b>Trolley Speed /min</b>	36 ft / 11 m (Opt. kit 69 ft / 21m)
<b>Insulation Grade</b>	F	<b>Trolley Number of Speeds</b>	1
<b>IEC Motor Protection</b>	IP55	<b>I-Beam Width Range</b>	82-178 mm
<b>Dynamic Brake</b>	Only with Optional VFD	<b>Minimum Turn Radius</b>	3 ft / 0.9 m
<b>Control</b>	Pendant Control and Optional Wireless	<b>Standards Compliance</b>	ASME HST-1 , ASME B30.16 , B30.17, EN60204-32
<b>Control Voltage</b>	24V	<b>Warranty</b>	3 Year

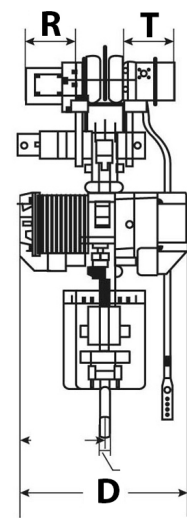
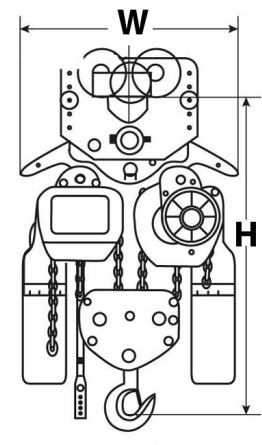
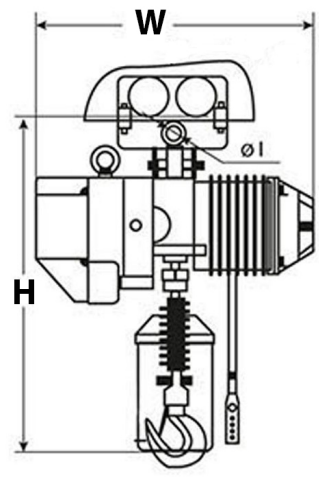
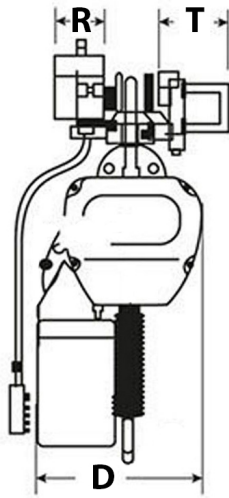

## Unit Weight & Dimensions

<b>T Trolley Motor Width</b>	6.14 in / 156 mm
<b>D Depth</b>	18 in / 450 mm
<b>R Trolley Cover Width</b>	8 in / 200 mm
<b>W Width</b>	30 in / 745 mm
<b>H Minimum Headroom</b>	25 in / 640 mm
<b>J Hook Opening</b>	1.6 in / 40 mm
<b>Total Unit Weight</b>	341 lbs / 155 Kg

## Packaging Weight & Dimensions

<b>Package 1 Net Weight</b>	341 lbs / 155 Kg
<b>Package 1 Width</b>	16 in / 40.64 cm
<b>Package 1 Gross Weight</b>	392 lbs / 178 Kg
<b>Package 1 Height</b>	33 in / 83.82 cm
<b>Package 1 Length</b>	28 in / 71.12 cm