



Electric Chain Hoist Power Trolley 2200 lbs. 20 ft. FEC Japan Chain 2 Speed

Key features

- Load Capacity: Handles up to 2,200 lbs. (1 ton), suitable for medium-duty lifting applications.
- Speed: Features dual-speed operation for enhanced control and flexibility during lifting.
- Power Trolley: Comes with a power trolley for smooth and efficient horizontal movement along the beam.
- 3 Year Warranty, Customer Support and Service in the USA

Electric Chain Hoist Description

This **M5 1 ton Two-Speed Electric Chain Hoist with Power Trolley** allows you to easily lift loads. This hoist comes with an electric trolley that can be quickly installed on an I-beam or crane. The powerful motor and three-phase connection are perfect for use in a wide variety of situations and environments. The quick-connect wiring system allows you get set up and started on your project in no time at all.

Prowinch Two Speed Electric Chain Hoist with Power Trolley

All of our Electric Chain Hoists are created with the goal of offering the best price-performance ratio. Key components such as lifespan factors are constantly tested and improved in order to offer the best product for the price.

Key Components

All internal components have been upgraded to meet the highest quality standards. Key electronic components are produced by American or German brands, and we use American-made lubricants to ensure the lifespan of gears and reducers. Final assembly and all tests are performed in the US before shipping to ensure that every unit meets the corresponding standard.

Duty Classification

Duty Classification is a key factor when choosing the right unit. These H4 hoists are suitable for high-volume handling in steel warehouses, machine shops, fabricating plants and mills, and foundries. For uniformly distributed work periods, the hoists have 50% max. operational time per hour and can handle up to 300 starts per hour. When being used for infrequent work periods, the hoist can be operated for 30 minutes from a cold start with up to 300 starts per hour. Operational time ratings are calculated at a 65% load factor, as per ASME HST-1-2012.

Control System

This electric chain hoist comes standard with a pendant control. The length of the control is 4 feet less than the lifting height, which allows it to be easily operated from ground-level. An optional wireless control is available for extra convenience.

Braking System

The electromagnetic brake system is tested at 125% of the hoist capacity and is designed to automatically engage immediately upon any loss of power.

Technical Specifications

Rated Load Capacity	2200 lb / 1000 kg	Emergency Stop	Yes
Standard Lifting Height	20 ft / 6 m	Contactor	EATON 12 AMP
Speed (f/m) / min	2.07 - 20.7 ft / 0.63 - 6.3 m	Transmission / Reducer Type	Spur gearbox with Oil splash lubrication
Number of Speeds	2 Speed	Load Chain Type	G80 JAPAN or G100
Capacity Range	2	Load Chain Size	7.1 x 21 mm
Voltage	3 Phase 208~240/440~480V 50/60Hz	Chain Falls	1
USA and Canada Voltage	208~240/440~480V	Chain Length	20 ft / 6 m
Available Voltages	208~240/440~480V for USA and 380/440~480V for CHILE	Humidity	<85%
FCC ID	WTX20X04015023E	Temperature	-4 ~ 104° F / -20 ~ 40° C
Duty Class	H4/M5/2m/Class D	Trolley Power	0.4 kW
Motor/Engine Power	1.8 kW	Noise Level	81 dB
Motor Brake	Yes DC Electromagnetic	Trolley Speed /min	36 - 68 ft /11 - 21 m
Insulation Grade	F	Trolley Number of Speeds	2
IEC Motor Protection	IP55	I-Beam Width Range	58 - 153 mm
Variable Fequency Driver	VFD Hitachi HS300-022H	Minimum Turn Radius	2.62 ft / 0.8 m
Dynamic Brake	Yes	Standards Compliance	ASME HST-1 , ASME B30.16 , B30.17, EN60204-32
Control	Pendant Control and Optional Wireless	Warranty	3 Year
Control Voltage	24V		

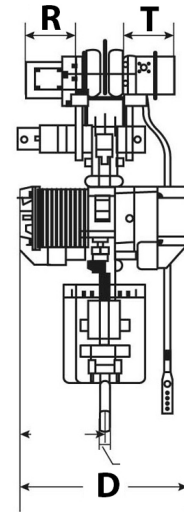
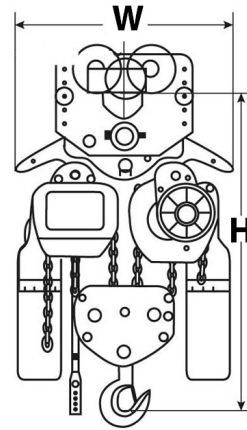
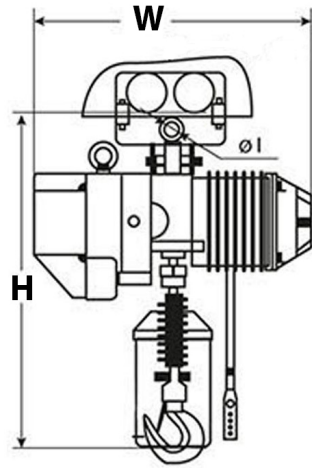
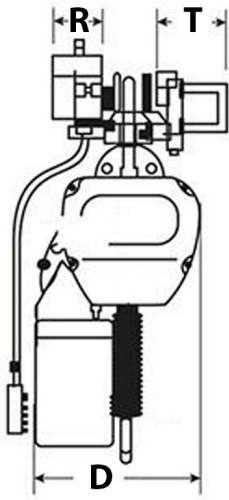

Unit Weight & Dimensions

T Trolley Motor Width	6.14 in / 156 mm
D Depth	13 in / 330 mm
R Trolley Cover Width	8 in / 200
W Width	25 in / 620 mm
H Minimum Headroom	17 in / 430 mm
J Hook Opening	1.3 in / 34 mm
Total Unit Weight	264 lbs / 120 Kg

Packaging Weight & Dimensions

Package 1 Net Weight	264 lbs / 120 Kg
Package 1 Width	14 in / 35.56 cm
Package 1 Gross Weight	295 lbs / 134 Kg
Package 1 Height	30 in / 76.2 cm
Package 1 Length	26 in / 66.04 cm