



20 ton 44000 lb 1 Speed 208~240/440~480V Electric Chain Hoist 40ft. G100 Chain H3 Duty

Key features

- Load Capacity: 20 ton (44000 lbs), ideal for very heavy lifting tasks.
- Voltage: 208~240/440~480V, compatible with multiple electrical systems.
- Speed Setting: 1 Speed, provides a steady and reliable lifting speed.
- 3 Year Warranty, Customer Support and Service in the USA

Electric Chain Hoist Description

Upgrade your heavy lifting with this powerful 20-ton (44000 lb) electric chain hoist, designed for 1-speed operation and compatible with 208~240/440~480V power sources. Featuring a 40 ft. G100 chain, it offers exceptional lifting capabilities and durability. The H3 Duty rating ensures reliable performance in demanding environments. Perfect for industrial applications requiring robust lifting solutions, this hoist delivers strength and efficiency to tackle the toughest jobs.

Prowinch Electric Chain Hoist

All of our Electric Chain Hoists are created with the goal of offering the best price-performance ratio. Key components such as lifespan factors are constantly tested and improved in order to offer the best product for the price.

Key Components

All internal components have been upgraded to meet the highest quality standards. Key electronic components are produced by American or German brands, and we use American-made lubricants to ensure the lifespan of gears and reducers. Final assembly and all tests are performed in the US before shipping to ensure that every unit meets the corresponding standard.

Duty Classification

Duty classification is a key factor when choosing the right unit. These H3 hoists are suitable for general machine shop fabricating, assembly, storage, and warehousing. For uniformly distributed work periods, the hoists have 25% max. operational time per hour and can handle up to 150 starts per hour. When being used for infrequent work periods, the hoist can be operated for 30 minutes from a cold start with up to 200 starts per hour. Operational time ratings are calculated at a 65% load factor, as per ASME HST-1-2012.

Control System

This electric chain hoist comes standard with a pendant control. The length of the control is 4 feet less than the lifting height, which allows it to be easily operated from ground-level. An optional wireless remote control is available for extra convenience.

Braking System

The electromagnetic brake system is tested at 125% of the hoist capacity and is designed to automatically engage immediately upon any loss of power.

Technical Specifications

Rated Load Capacity	44000 lb / 20000 kg	Control Voltage	24V
Standard Lifting Height	40 ft / 12 m	Emergency Stop	Yes
Speed (f/m) / min	4.6ft/1.4m@60Hz 3.8ft/1.2m@50Hz	Contactors	EATON 25 AMP
Number of Speeds	1 Speed	Transmission / Reducer Type	Spur gearbox with Oil splash lubrication
Voltage	3 Phase 208~240/440~480V 50/60Hz	Load Chain Type	G100
Available Voltages	208~240/440~480V for USA and 380/440~480V for CHILE	Load Chain Size	11.2x34 mm
Duty Class	H3/M4/1Am/Class C	Chain Falls	8
Motor Power (6)	3.0 kW x 2	Chain Length	320 ft / 97 m
Motor AMP	20 / 10	Humidity	<85%
Motor RPM	1728@60Hz 1440@50HZ	Temperature	-4 ~ 104° F / -20 ~ 40° C
Motor Brake	Yes	Noise Level	81 dB
Insulation Grade	F	Standards Compliance	ASME HST-1 , ASME B30.16, EN60204-32
IEC Motor Protection	IP55	Warranty	3 Year
Control	Pendant Control and Optional Wireless		

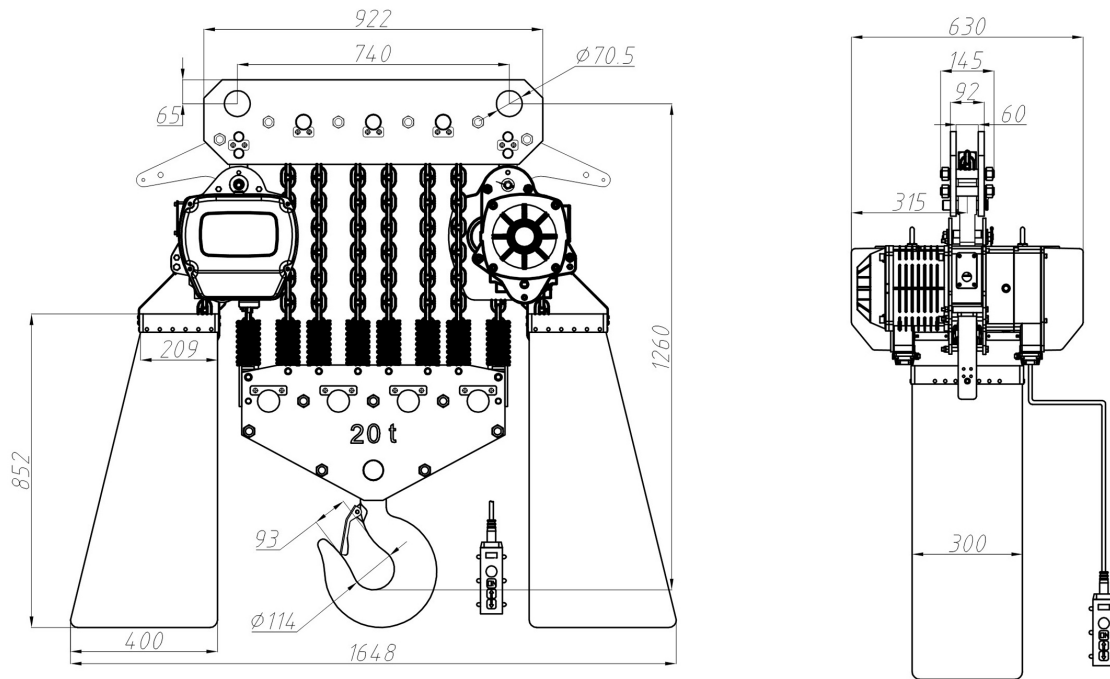

Unit Weight & Dimensions

H Minimum Headroom	64 in / 1610 mm
W Width	25 in / 630 mm
D Depth	50 in / 1259 mm
J Hook Opening	93
Total Unit Weight	1584 lbs / 719 Kg

Packaging Weight & Dimensions

Package 1 Net Weight	1584 lbs / 719 Kg
Package 2 Gross Weight	111 lbs / 50 Kg
Package 1 Gross Weight	1694 lbs / 769 Kg
Package 2 Length	38 in / 96.52 cm
Package 1 Length	53 in / 134.62 cm
Package 2 Width	22 in / 55.88 cm
Package 1 Width	33 in / 83.82 cm
Package 2 Height	39 in / 99.06 cm
Package 1 Height	54 in / 137.16 cm