



## 2200 Lb 1000 Kg BLACK Chain Stage Hoist 80 ft Wireless 220/440 50/60HZ 3 Ph

### Key features

- 3 Year Warranty, Customer Support and Service in the USA

2200 Lb 1000 Kg BLACK Chain Stage Hoist 80 ft Wireless 220/440 50/60HZ 3 Ph

## Technical Specifications

<b>Rated Load Capacity</b>	2200 lb / 1000 kg	<b>IEC Motor Protection</b>	IP54
<b>Voltage</b>	1 Phase 220~240V 50/60Hz	<b>Load Chain Type</b>	G80
<b>Total Power Watts</b>	1.5 kW	<b>Warranty</b>	3 Year

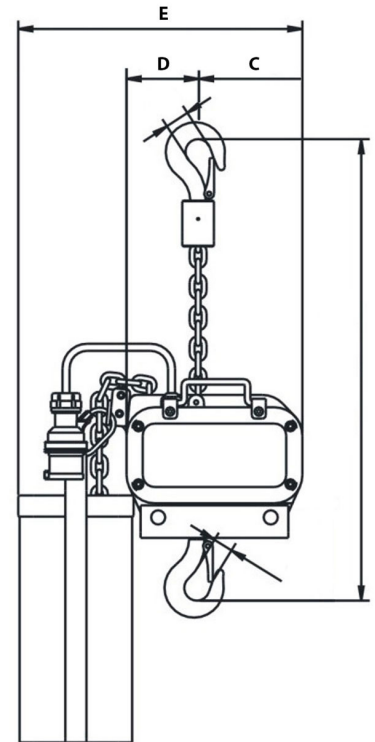
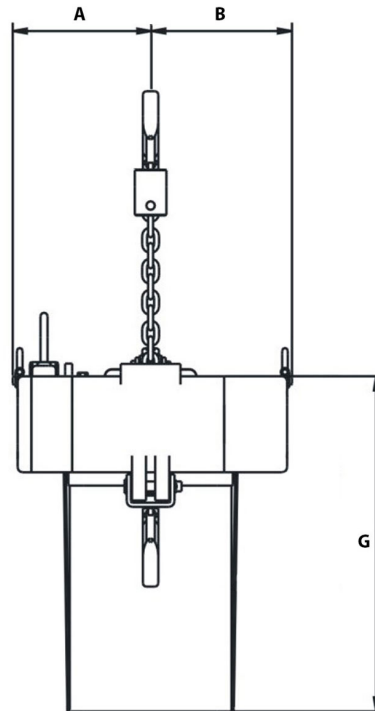
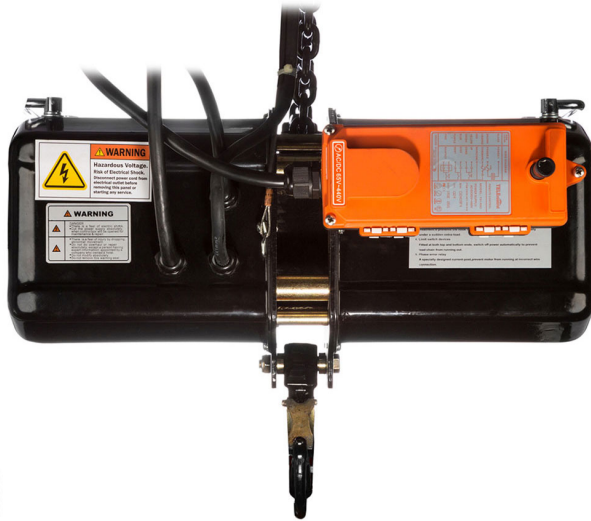

Pendant Control and Wireless Remote Control

Dimensions	A	B	C	D	E	F	G
PWR025SHSF	8.3 in / 210 mm	4.6 in / 116 mm	4.1 in / 104 mm	12.6 in / 320 mm	0.94 in / 24 mm	19.7 in / 500 mm	
PWR050SHSF	9.6 in / 245 mm	6.2 in / 158 mm	5.6 in / 142 mm	15.8 in / 402 mm	1.3 in / 33 mm	21.7 in / 550 mm	
PWR100SHSF	9.6 in / 245 mm	6.2 in / 158 mm	5.6 in / 142 mm	15.8 in / 402 mm	1.3 in / 33 mm	21.7 in / 550 mm	
PWR200SHSF	9.6 in / 245 mm	4.9 in / 124 mm	6.9 in / 176 mm	15.8 in / 402 mm	1.6 in / 40 mm	25.6 in / 650 mm	