



Heavy Duty 5 Ton Capacity Manual Chain Trolley 10000 lb Geared

Key features

- US and EC Standards ASME HST-1 , ASME B30.17 , EN14492-2 , EN60204-32
- Equipped with rubber bump stops and safety pins for enhanced safety and protection
- Manual Operation: Geared for manual control, providing versatility in handling various tasks
- Durable construction for long-term reliability and performance, Compatible S-beam and W-beam
- 3 Year Warranty, Customer Support and Service in the USA

Heavy Duty 5 Ton Capacity Manual Chain Trolley 10000 lb Geared Description

The Heavy Duty 5 Ton Capacity Manual Chain Trolley is an exceptional material handling solution designed to lift and transport loads up to 10,000 lbs (5 tons). Featuring a geared manual chain system, this trolley provides smooth and controlled movement along standard I-beams or tracks, making it perfect for various industrial applications, including warehouses and construction sites. Its manual operation allows for effortless maneuverability without the need for electrical power, offering flexibility in different environments. Crafted from high-quality materials, this heavy-duty trolley ensures durability and long-lasting performance, making it an essential tool for safe and efficient material handling.

Technical Specifications

| | | | |
|----------------------------|---------------------|----------------------------|----------------|
| Rated Load Capacity | 11000 lb / 5000 kg | Minimum Turn Radius | 4.3 ft / 1.5 m |
| I-Beam Width Range | 4-7 in / 100-200 mm | Warranty | 3 Year |

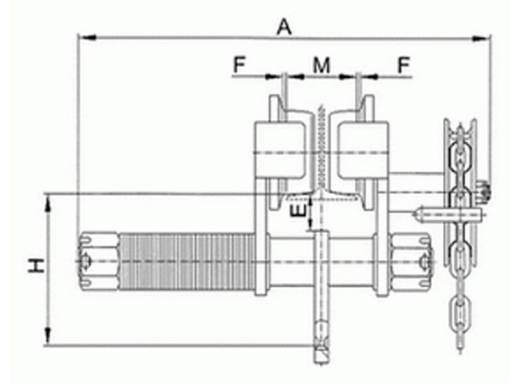
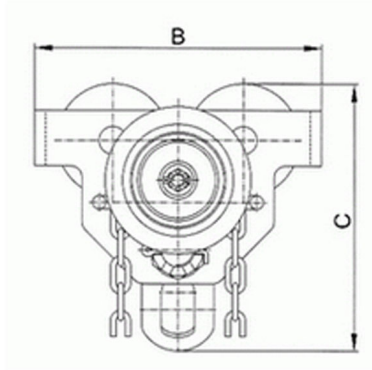

| Model / Modelo | | PWQMC05T | PWQMC1T | PWQMC3T | PWQMC5T | PWQMC10T | PWQMC20T |
|--------------------------|---|-----------------|------------------|------------------|--------------------|------------------|------------------|
| Dimensions / Dimensiones | A | 9.8 in / 250 mm | 10.2 in / 260 mm | 13 in / 330 mm | 14.6 in / 370 mm | 15.7 in / 400 mm | 16.9 in / 430 mm |
| | B | 7.7 in / 195 mm | 8.3 in / 210 mm | 11.8 in / 300 mm | 13.7 in / 334.5 mm | 18.1 in / 460 mm | 22.8 in / 580 mm |
| | C | 7.1 in / 180 mm | 7.9 in / 200 mm | 9 in / 228.5 mm | 13.7 in / 334.5 mm | 19.3 in / 490 mm | 19.7 in / 500 mm |
| | H | 3.5 in / 90 mm | 3.7 in / 95 mm | 5.5 in / 140 mm | 6.7 in / 170 mm | 10.8 in / 275 mm | 11 in / 280 mm |

Unit Weight & Dimensions

| | |
|--------------------------|----------------|
| Total Unit Weight | 90 lbs / 41 Kg |
|--------------------------|----------------|

Packaging Weight & Dimensions

| | |
|-------------------------------|------------------|
| Package 1 Net Weight | 90 lbs / 41 Kg |
| Package 1 Width | 14 in / 35.56 cm |
| Package 1 Gross Weight | 92 lbs / 42 Kg |
| Package 1 Height | 13 in / 33.02 cm |
| Package 1 Length | 9 in / 22.86 cm |