



## Wire Rope Pulley 10 Ton

### Key features

- **Load Capacity:** Supports loads up to 10 tons, providing the strength needed for demanding tasks.
- **Durable Construction:** Crafted from high-quality materials, ensuring longevity and resistance to wear and tear in harsh environments.
- **Smooth Operation:** Designed for easy cable management, reducing friction and wear on the wire rope for improved efficiency.
- **3 Year Warranty, Customer Support and Service in the USA**

### Wire Rope Pulley 10 Ton Description

The Wire Rope Pulley designed for 10 tons is an essential tool for efficient heavy lifting and material handling. This high-capacity pulley is engineered for optimal performance, making it ideal for construction, industrial, and rigging applications where strength and reliability are crucial.

### Prowinch Snatch Blocks Pulleys

All of our **Snatch Blocks Pulleys** are created with the goal of offering the best quality and performance. Key components such as lifespan factors are constantly tested and improved in order to offer the best product for the price.

## Technical Specifications

<b>Rated Load Capacity</b>	22046 lb / 10000 kg	<b>Design Factor</b>	4:1
<b>Recommended wire rope</b>	15/16 ~ 1 in / 24 ~ 26 mm	<b>Warranty</b>	3 Year
<b>Pulley Diameter</b>	Ø9.8 in / Ø250 mm		

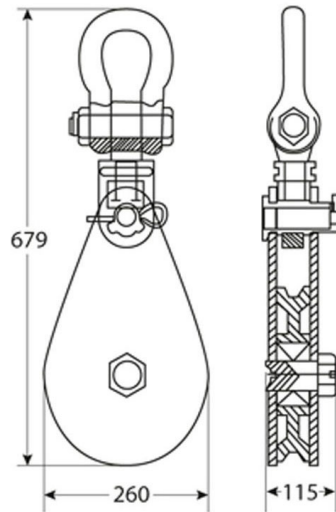

Dimensions in mm / Dimensiones en mm

## Unit Weight & Dimensions

<b>Total Unit Weight</b>	77 lbs / 35 Kg
--------------------------	----------------

## Packaging Weight & Dimensions

<b>Package 1 Net Weight</b>	77 lbs / 35 Kg
<b>Package 1 Width</b>	27 in / 68.58 cm
<b>Package 1 Gross Weight</b>	79 lbs / 36 Kg
<b>Package 1 Height</b>	5 in / 12.7 cm
<b>Package 1 Length</b>	10 in / 25.4 cm