



2000 lbs Davit Crane 360 Swivel with Wireless Electric Winch 220V

Key features

- Load Capacity: Supports up to 2000 lbs, making it suitable for a wide range of heavy lifting tasks.
- Wireless Electric Winch: Remote control operation allows for easy and convenient lifting and lowering. Adjustable telescopic boom system with 3 heights and positions.
- Durable Construction: Built from high-quality materials for strength and reliability under heavy loads.
- Removable boom for easy transportation and storage.
- 1 Year Warranty, Customer Support and Service in the USA

Davit Crane with Wireless Electric Winch Description

The 2000 lbs Davit Crane with Wireless Electric Winch is a powerful lifting solution designed for heavy-duty applications. With a capacity of up to 2000 pounds, this crane features a wireless electric winch for effortless operation and a 360-degree swivel for maximum maneuverability. Ideal for workshops, warehouses, and construction sites, this crane enhances efficiency and safety in various lifting tasks.

Prowinch Davit Cranes

All of our Davit Cranes are created with the goal of offering the best price-performance ratio. Key components such as lifespan factors are constantly tested and improved in order to offer the best product for the price.

Key Components

All internal components have been upgraded to meet the highest quality standards. Final assembly and all tests are performed in the US before shipping to ensure that every unit meets the corresponding standard.

Duty Classification

Duty classification is a key factor when choosing the right unit. This davit crane comes with an H1 electric wire rope hoist that is suitable for infrequent handling, installing and servicing heavy equipment, and idling for long periods between use. For uniformly distributed work periods, the hoist has a 12.5% max. operational time per hour and can handle up to 75 starts per hour. When being used for infrequent work periods, the hoist can be operated for 15 minutes from a cold start with up to 100 starts per hour. Operational time ratings are calculated at a 65% load factor, as per ASME Standards.

Braking System

The electromagnetic brake system is tested at 125% of the hoist capacity and is designed to automatically engage immediately upon any loss of power.

Technical Specifications

Rated Load Capacity	1000 kg / 2200 lbs	Insulation Grade	B
Speed (f/m) / min	10m/min @ 1 linea 5 m/min @ 2 lineas	IEC Motor Protection	IP40
Number of Speeds	1 Speed	Wire Rope	ø5.58 mm x 12 m
Voltage	1 Phase 220~240V 50/60Hz	Humidity	<85%
FCC ID	OFNF21	Temperature	-4°~104° F / -20°~40° C
Duty Class	H2/M3/1Bm/Class B	Noise Level	71 dB
Motor Power (6)	1600 W	Standards Compliance	Intertek 4006091 , UL N 1340, CAN/CSA C22.2 , EN14492-2 , EN60204-32
Motor Brake	YES	Warranty	1 Year

BOOM Position	1100 lb - 0.5 t		
	1	2	3
A	1300 lbs	660 lbs	340 lbs
B	1150 lbs	580 lbs	290 lbs
C	1100 lbs	550 lbs	280 lb

BOOM Position	2200 lb - 1 t		
	1	2	3
A	2600 lbs	1300 lbs	780 lbs
B	2300 lbs	1150 lbs	690 lbs
C	2200 lbs	1100 lbs	660 lb

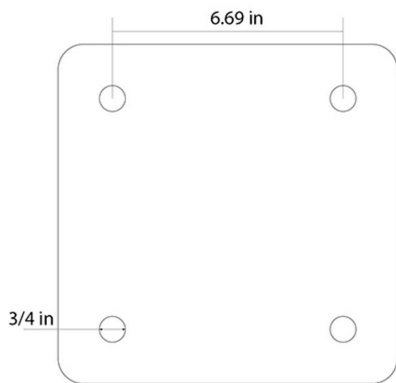
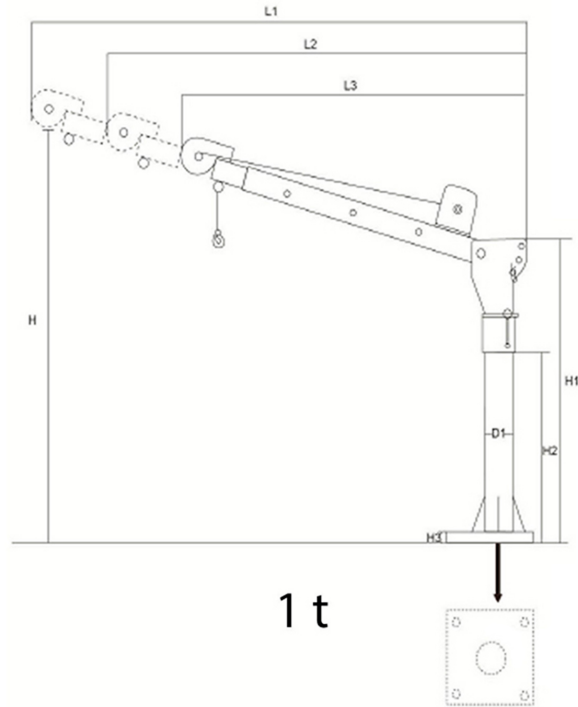
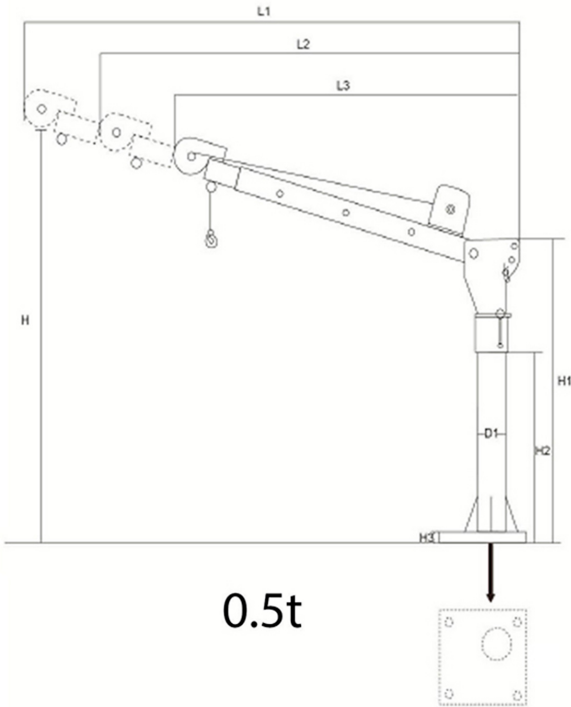

Variable	Capacity	
	1120 lb / 0.5 t	2240 lb / 1 t
H	82 in / 2082 mm	85 in / 2159 mm
H1	46.5 in / 1181 mm	47 in / 1193 mm
H2	30 in / 762 mm	
H3	3/4 in /	3/4 in /
L1	49 in / 1244 mm	51 in / 1295 mm
L2	42 in / 1066 mm	44 in / 1117 mm
L3	35 in / 889 mm	40 in / 1016 mm
D1	3.5 in / 88.9 mm	4 in / 101.6

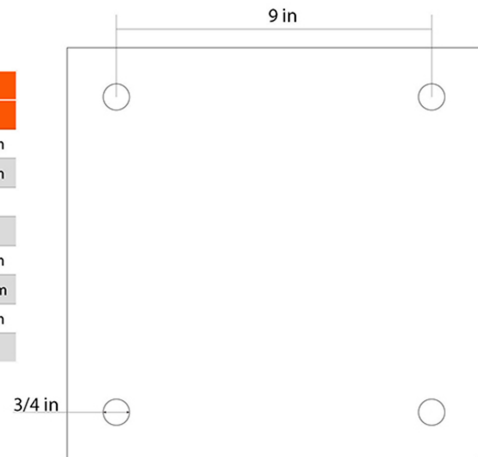

Unit Weight & Dimensions

Packaging Weight & Dimensions

Total Unit Weight	281 lbs / 128 Kg	Package 1 Net Weight	88 lbs / 40 Kg
		Package 3 Net Weight	42 lbs / 19 Kg
		Package 1 Gross Weight	108 lbs / 49 Kg
		Package 3 Gross Weight	46 lbs / 21 Kg
		Package 1 Length	48 in / 121.92 cm
		Package 3 Length	18 in / 45.72 cm
		Package 1 Width	15 in / 38.1 cm
		Package 3 Width	9 in / 22.86 cm
		Package 1 Height	10 in / 25.4 cm
		Package 3 Height	9 in / 22.86 cm
		Package 2 Net Weight	85 lbs / 39 Kg
		Package 4 Net Weight	66 lbs / 30 Kg
		Package 2 Gross Weight	100 lbs / 45 Kg
		Package 4 Gross Weight	70 lbs / 32 Kg
		Package 2 Length	38 in / 96.52 cm
		Package 4 Length	21.65 in / 54.99 cm
		Package 2 Width	13 in / 33.02 cm
		Package 4 Width	9.53 in / 24.21 cm
		Package 2 Height	15 in / 38.1 cm
		Package 4 Height	13.19 in / 33.5 cm