



5 Tons Single Girder Top Running Underhung Hoist Crane 20m

Key features

- **Load Capacity:** Capable of lifting up to 5 tons, making it suitable for a wide range of applications in manufacturing, warehouses, and workshops.
- **Top Running Configuration:** Allows for smooth operation along the runway, enhancing workflow efficiency and reducing downtime.
- **Durable Construction:** Constructed from high-quality materials to withstand rigorous use and ensure long-lasting performance in demanding environments.
- **3 Year Warranty, Customer Support and Service in the USA**

The 5 Tons Single Girder Top Running Underhung Hoist Crane Description

The 5 Tons Single Girder Top Running Underhung Hoist Crane is designed for efficient and reliable lifting in a variety of industrial settings. This crane offers a robust solution for handling loads up to 5 tons while maximizing operational space.

Technical Specifications

Warranty	3 Year
----------	--------



Model/Modelo	PWRCSB
Capacity / Capacidad	11023 lb / 5000 kg
Speed (per min) / Velocidad (por min)	3-8.9 ft / 0.9-2.7 m
Lifting Height / Altura de Izaje	13.1 ft / 4 m
Motor Power / Potencia de Motor	1.0 - 3.0 kW
Control Voltage / Voltaje Control	24V
Motor Rev. / Rev. Motor	1440 RPM
Insulation Grade / Grado de Aislacion	F
Traveling Speed (per min) / Velocidad de Traslado (por min)	36 - 68 ft / 11-21 m
I Beam / Viga I	3.94 - 7.01 in / 100 - 178 mm
Min. Turn Radius / Radio Mínimo de Giro	4.9 ft / 1.5 m
Load Chain Grade / Grado de la Cadena de Carga	80 FEC
Chain Size / Dimensiones de la Cadena	Ø7/16 in x 11.2 mm Ø59.1 ft x 18 ft
Chain Falls / Calzas de Cadena	2
Bearings / Rodamientos	SNK
Net Weight / Peso Neto	582 lb / 264 kg
Standard / Norma	ASME B30.17



Model/Modelo	PWMVSL6
Capacity / Capacidad	11023 lb / 5000 kg
Lifting Height / Altura de Izaje	13.1 ft / 4 m
Span / Luz	19.7 ft / 6.0 m
Traveling Length / Longitud de Recorrido	65.6 ft / 20 m
Duty Class / Clase de Servicio	M4

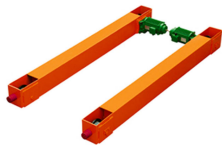
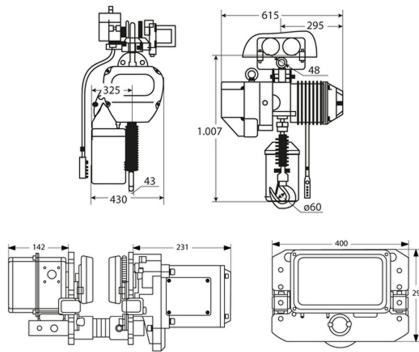

Model/Modelo	PWETST200
Capacity / Capacidad	11023 lb / 5000 kg
Traveling Speed (per min) / Velocidad Desplazamiento (por min)	16 - 59 ft / 5 - 18 m
Motor Power / Potencia Motor	2 x 0.4 kW
Length / Longitud	6.56 ft / 2 m
Wheels Diameter / Diámetro de Ruedas	Ø7.68 in / Ø195 mm

Country / Pais	Triphase / Trifasico
Argentina	380V @ 50Hz
Chile	380V @ 50Hz
Colombia	220V/440v @ 60Hz
Costa Rica	220V/440v @ 60Hz
Mexico	220V/440v @ 60Hz
Peru	220V/440v @ 60Hz
USA	220V/440v @ 60Hz

Check for options / Consulte por opciones

Warranty: 3 Year / Certification valid for 1 year / 10 year parts and service availability
Garantía: 3 Años / Certificación válida por 1 año / 10 Años disponibilidad de piezas y servicio

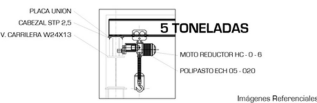
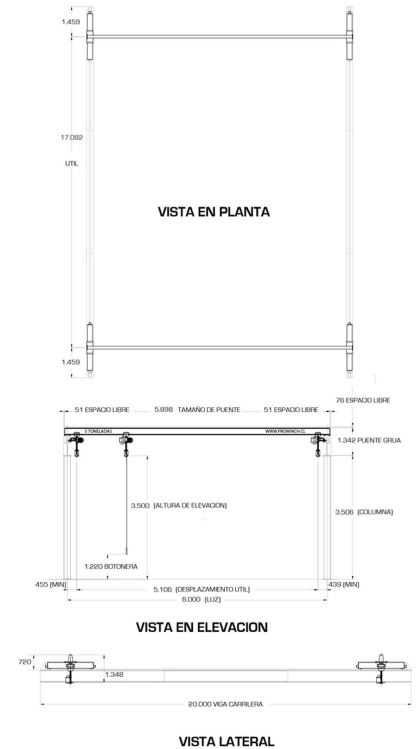

Imágenes Referenciales