



3 Ton Underhung Motorized End Trucks Single Girder up to 40ft Span 220/440V 3P

Key features

- Load Capacity: Supports up to 3 tons, making it suitable for moderate to heavy lifting requirements.
- Power Supply: Operates on 220/440V 3-phase power, ensuring consistent and dependable motorized operation.
- Versatile Applications: Ideal for use in warehouses, manufacturing facilities, and other industrial environments where efficient lifting solutions are needed.
- 3 Year Warranty, Customer Support and Service in the USA

The 3 Ton Underhung Motorized End Trucks Description

The 3 Ton Underhung Motorized End Trucks are designed for single girder applications, accommodating spans of up to 40 feet. With a power supply of 220/440V 3-phase, this system delivers reliable and efficient performance for a variety of overhead lifting tasks in industrial settings.

Technical Specifications

Rated Load Capacity	3 ton	Motor Brake	Yes
Speed (f/m) / min	66 ft	IEC Motor Protection	IP54
Number of Speeds	1 Speed - Optional Variable Speed	Variable Frequency Driver	Optional 1.5 Kw
Voltage	3 Phase 220~240/440~480V 60Hz	Dynamic Brake	Only with VFD Optional
Total Power Watts	0.25Kw x 4	Control	Not Included. Optional single Speed, 2 Speed and Variable Speed
Max. Span	30 ft	I-Beam Width Range	110 - 300 mm (4.33 - 11.8 in)
Material	Steel	Standards Compliance	ASME / CMAA / Nch
Duty Class	H4/M5/2m/Class D	Warranty	3 Year

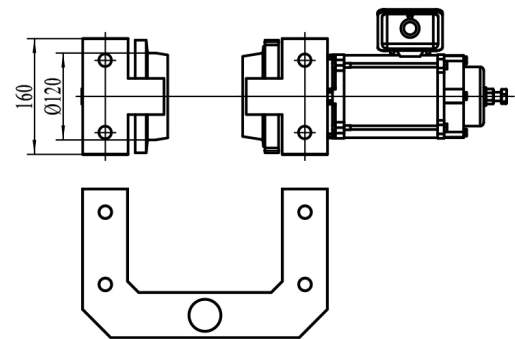
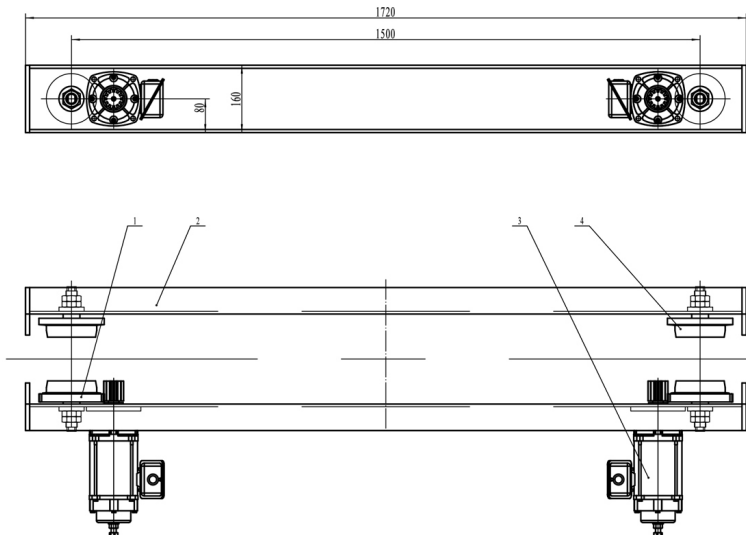

Unit Weight & Dimensions

End-Truck Length	1500 mm
-------------------------	---------

Packaging Weight & Dimensions

Package 1 Gross Weight	633 lbs / 287 Kg
Package 1 Width	16 in / 40.64 cm
Package 1 Length	73 in / 185.42 cm
Package 1 Height	28 in / 71.12 cm