

2 Ton Underhung Motorized End Trucks Single Girder up to 34ft Span 220/440V 3P

Key features

- **Load Capacity:** Supports up to 2 tons, making it suitable for moderate lifting requirements.
- **Power Supply:** Operates on 220/440V 3-phase power, ensuring consistent and dependable motorized performance.
- **Versatile Applications:** Suitable for use in warehouses, manufacturing facilities, and other industrial settings where efficient lifting solutions are needed.
- **3 Year Warranty, Customer Support and Service in the USA**

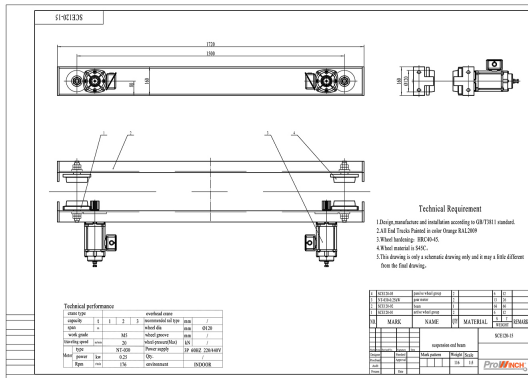

The 2 Ton Underhung Motorized End Trucks Description

The 2 Ton Underhung Motorized End Trucks are designed for single girder applications, accommodating spans of up to 34 feet. Operating on a 220/440V 3-phase power supply, this system delivers reliable and efficient performance for various overhead lifting tasks in industrial environments.

Technical Specifications

Rated Load Capacity	2 ton	Motor Brake	Yes
Speed (f/m) / min	66 ft	IEC Motor Protection	IP54
Number of Speeds	1 Speed - Optional Variable Speed	Variable Frequency Driver	Optional 1.5 Kw
Voltage	3 Phase 220~240/440~480V 60Hz	Dynamic Brake	Only with VFD Optional
Total Power Watts	0.25Kw x 4	Control	Not Included. Optional single Speed, 2 Speed and Variable Speed
Max. Span	40 ft	I-Beam Width Range	110 - 300 mm (4.33 - 11.8 in)
Material	Steel	Standards Compliance	ASME / CMAA / Nch
Duty Class	H4/M5/2m/Class D	Warranty	3 Year

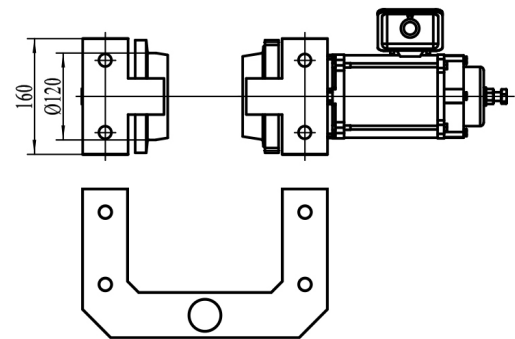
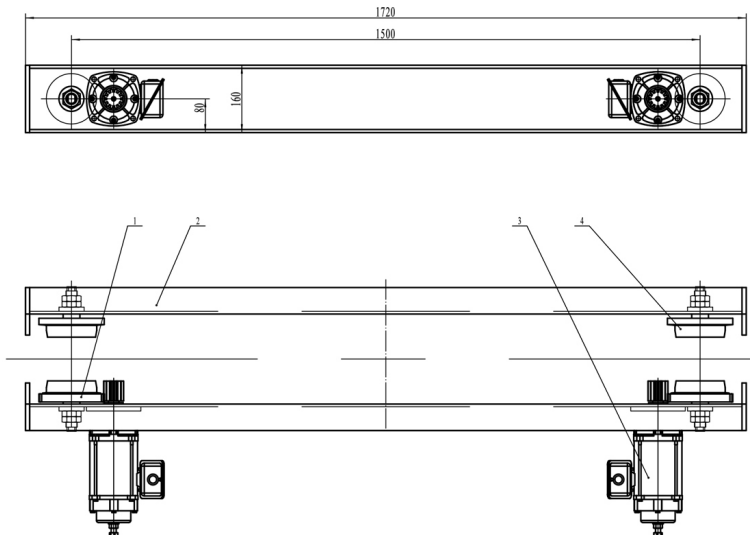

Unit Weight & Dimensions

End-Truck Length	1500 mm
-------------------------	---------

Packaging Weight & Dimensions

Package 1 Gross Weight	556 lbs / 252 Kg
-------------------------------	------------------