



2 Ton Top Running Motorized End Trucks Single Girder up to 57ft Span 220/440V 3P

Key features

- Load Capacity: Supports up to 2 tons, perfect for moderate lifting tasks in industrial environments.
- Power Supply: Operates on 220/440V 3-phase power, ensuring consistent and reliable motorized performance.
- Versatile Applications: Ideal for use in warehouses, manufacturing facilities, and other moderate industrial applications.
- 3 Year Warranty, Customer Support and Service in the USA

The 2 Ton Top Running Motorized End Trucks Description

The 2 Ton Top Running Motorized End Trucks are engineered for single girder applications, accommodating spans of up to 57 feet. Designed for efficiency and reliability, this system operates on a 220/440V 3-phase power supply, making it suitable for various overhead lifting tasks.

Technical Specifications

Rated Load Capacity	2 Ton	Motor Brake	Yes
Speed (f/m) / min	66 ft	IEC Motor Protection	IP54
Number of Speeds	1 Speed - Optional Variable Speed	Variable Frequency Driver	Optional 1.1 Kw
Voltage	3 Phase 220~240/440~480V 60Hz	Dynamic Brake	Only with VFD Optional
Total Power Watts	0.25 x 2	Control	Not Included. Optional single Speed, 2 Speed and Variable Speed
Max. Span	60 Ft	I-Beam Width Range	Any
Material	Steel	Standards Compliance	ASME / CMAA / Nch
Duty Class	H4/M5/2m/Class D	Warranty	3 Year

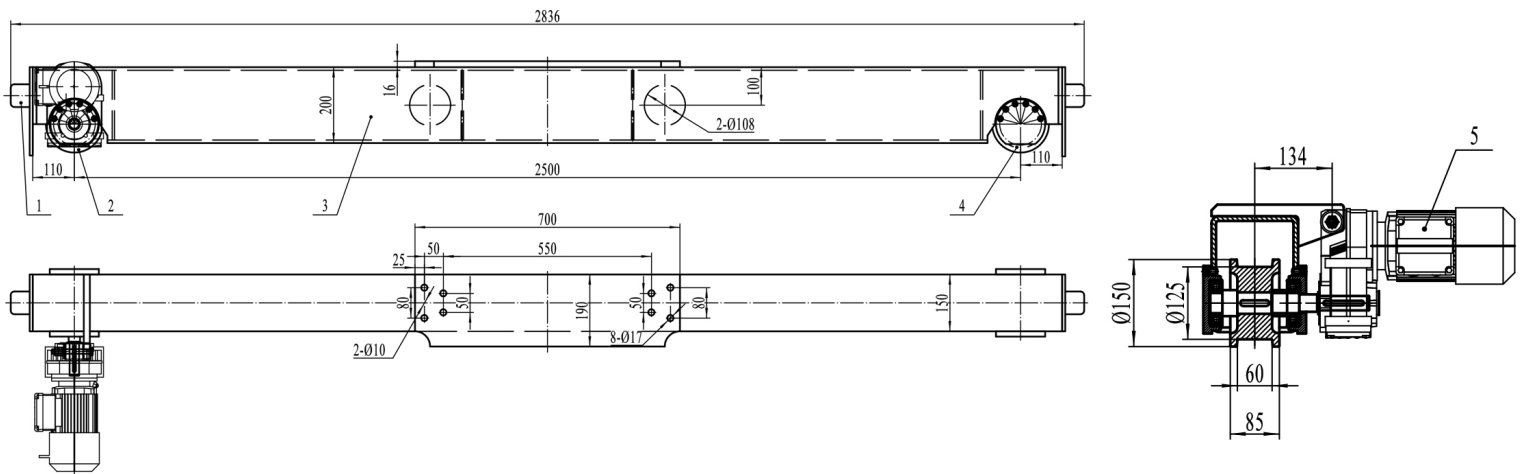

Unit Weight & Dimensions

End-Truck Length	2500 mm
-------------------------	---------

Packaging Weight & Dimensions

Package 1 Gross Weight	977 lbs / 443 Kg
Package 1 Width	24 in / 60.96 cm
Package 1 Length	119 in / 302.26 cm
Package 1 Height	31 in / 78.74 cm