

1 Ton Top Running Motorized End Trucks Single Girder up to 34ft Span 220/440V 3P



Key features

- Load Capacity: Supports up to 1 ton, suitable for lighter lifting applications.
- Power Supply: Operates on 220/440V 3-phase power, delivering consistent and reliable power for motorized operation.
- Versatile Applications: Ideal for warehouses, manufacturing facilities, and light-duty industrial operations.
- 3 Year Warranty, Customer Support and Service in the USA

The 1 Ton Top Running Motorized End Trucks Description

The 1 Ton Top Running Motorized End Trucks are designed for single girder applications, accommodating spans of up to 34 feet. This robust system operates on a 220/440V 3-phase power supply, ensuring efficient and reliable performance for various overhead lifting tasks.

Technical Specifications

Rated Load Capacity	1 Ton	Motor Brake	Yes
Speed (f/m) / min	66 ft	IEC Motor Protection	IP54
Number of Speeds	1 Speed - Optional Variable Speed	Variable Frequency Driver	Optional 1.1 Kw
Voltage	3 Phase 220~240/440~480V 60Hz	Dynamic Brake	Only with VFD Optional
Total Power Watts	0.25 x 2	Control	Not Included. Optional single Speed, 2 Speed and Variable Speed
Max. Span	50 Ft	I-Beam Width Range	Any
Material	Steel	Standards Compliance	ASME / CMAA / Nch
Duty Class	H4/M5/2m/Class D	Warranty	3 Year

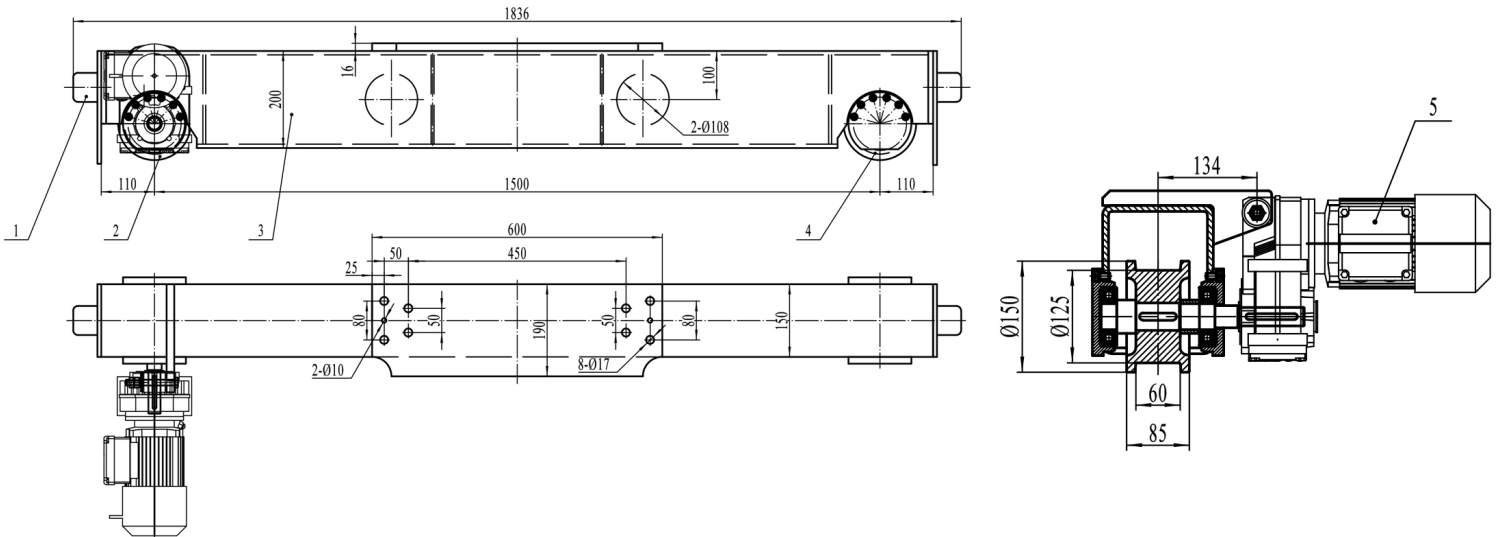

Unit Weight & Dimensions

End-Truck Length	1500 mm
-------------------------	---------