



5 Ton Fixed Height Steel Gantry Crane 12 ft Height 12 ft Span MADE IN USA

Key features

- Load Capacity: Supports up to 5 tons, perfect for heavy lifting needs
- All-Steel Construction
- Durable Steel Construction: Crafted from high-quality steel for maximum strength and stability.
- User-Friendly Design: Simple manual operation for easy lifting and lowering of loads.
- Super-strong swivel casters (all locking) with rubber for smooth rolling
- 3 Year Warranty, Customer Support and Service in the USA

Fixed Height Steel Gantry Crane Description

The 5 Ton Fixed Height Steel Gantry Crane is a heavy-duty lifting solution designed to support loads of up to 5 tons. With a fixed height of 12 feet and a 12-foot span, this crane is ideal for a variety of industrial and workshop applications. Proudly made in the USA, it features durable steel construction for reliable performance in material handling tasks.

Technical Specifications

Rated Load Capacity	5 ton	Material	Steel
I-Beam Height	21 in	Design Factor	4:1
Overall SPAN	12 ft	I-Beam Width Range	8.24 in
Clear SPAN	10 ft	Made in	USA
HUB Height Under The Beam	11 ft	Warranty	3 Year

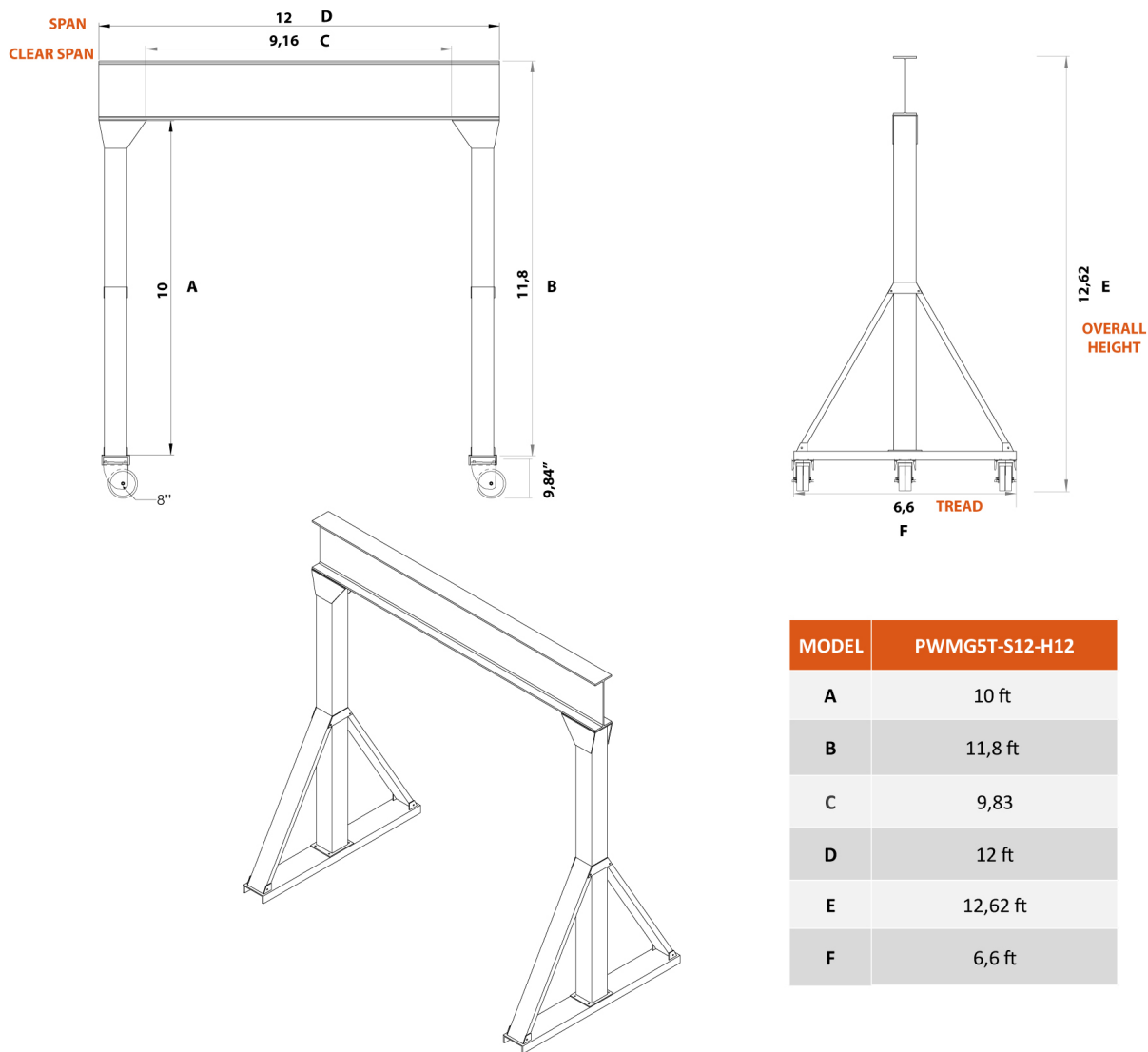

MODEL	PWMG5T-S12-H12
A	10 ft
B	11,8 ft
C	9,83
D	12 ft
E	12,62 ft
F	6,6 ft

Unit Weight & Dimensions

Total Unit Weight	1850 lbs / 840 Kg
--------------------------	-------------------

Packaging Weight & Dimensions

Package 1 Net Weight	1850 lbs / 839 Kg
-----------------------------	-------------------

Package 1 Width	145 in / 368.3 cm
------------------------	-------------------

Package 1 Gross Weight	2218 lbs / 1006 Kg
-------------------------------	--------------------

Package 1 Height	31 in / 78.74 cm
-------------------------	------------------

Package 1 Length	43 in / 109.22 cm
-------------------------	-------------------