



3 Ton Adjustable Telescoping Gantry Crane 11~15 ft Height 8 ft Span **MADE IN USA**

Key features

- Load Capacity: Supports up to 3 tons, perfect for heavy lifting operations.
- Durable Construction: Built with high-quality materials for stability and long-lasting performance.
- Adjustable Height: Height can be easily adjusted from 11 to 15 feet to accommodate different needs.
- Super-strong swivel casters (all locking) with rubber for smooth rolling
- 3 Year Warranty, Customer Support and Service in the USA

Adjustable Telescoping Gantry Crane Description

The Manual Gantry Crane is a robust lifting solution designed to support loads of up to 3 tons. With an adjustable height range of 11 to 15 feet and an 8-foot span, this crane is ideal for various industrial and workshop applications. Proudly made in the USA, it features durable construction for reliable performance in material handling tasks.

Technical Specifications

Rated Load Capacity	3 ton	Material	Steel
I-Beam Height	12 in	Design Factor	4:1
Overall SPAN	8 ft	I-Beam Width Range	6.4 in
Clear SPAN	6 ft	Made in	USA
HUB Height Under The Beam	11 to 15 ft	Warranty	3 Year

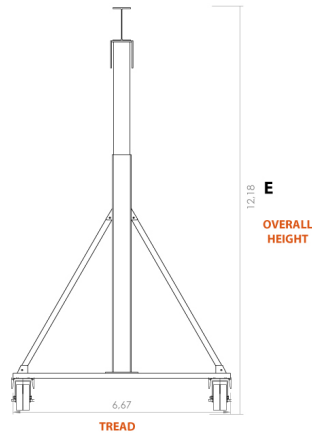
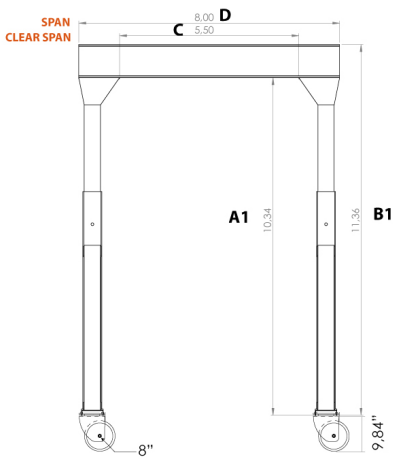

MODEL	PWMG3T-S8-H11-15a
A1	10,34 ft
B1	11,36 ft
C	5,5
D	8,0
E	12,18
A2	11,36
B2	14,36
F	15,18

