



3 Ton Fixed Height Steel Gantry Crane 12 ft Height 12 ft Span MADE IN USA

Key features

- Load Capacity: Supports up to 3 tons, suitable for heavy lifting operations.
- Durable Steel Construction: Crafted from high-quality steel for maximum stability and longevity.
- Height: Fixed at 12 feet, providing sufficient clearance for a variety of applications.
- Super-strong swivel casters (all locking) with rubber for smooth rolling
- 3 Year Warranty, Customer Support and Service in the USA

Fixed Height Steel Gantry Crane Description

The 3 Ton Fixed Height Steel Gantry Crane is a heavy-duty lifting solution designed to support loads of up to 3 tons. With a fixed height of 12 feet and a 12-foot span, this crane is ideal for various industrial and workshop applications. Proudly made in the USA, it features durable steel construction, ensuring reliable performance for your material handling tasks.

Technical Specifications

Rated Load Capacity	3 ton	Material	Steel
I-Beam Height	12 in	Design Factor	4:1
Overall SPAN	12 ft	I-Beam Width Range	6.4 in
Clear SPAN	10 ft	Made in	USA
HUB Height Under The Beam	11 ft	Warranty	3 Year

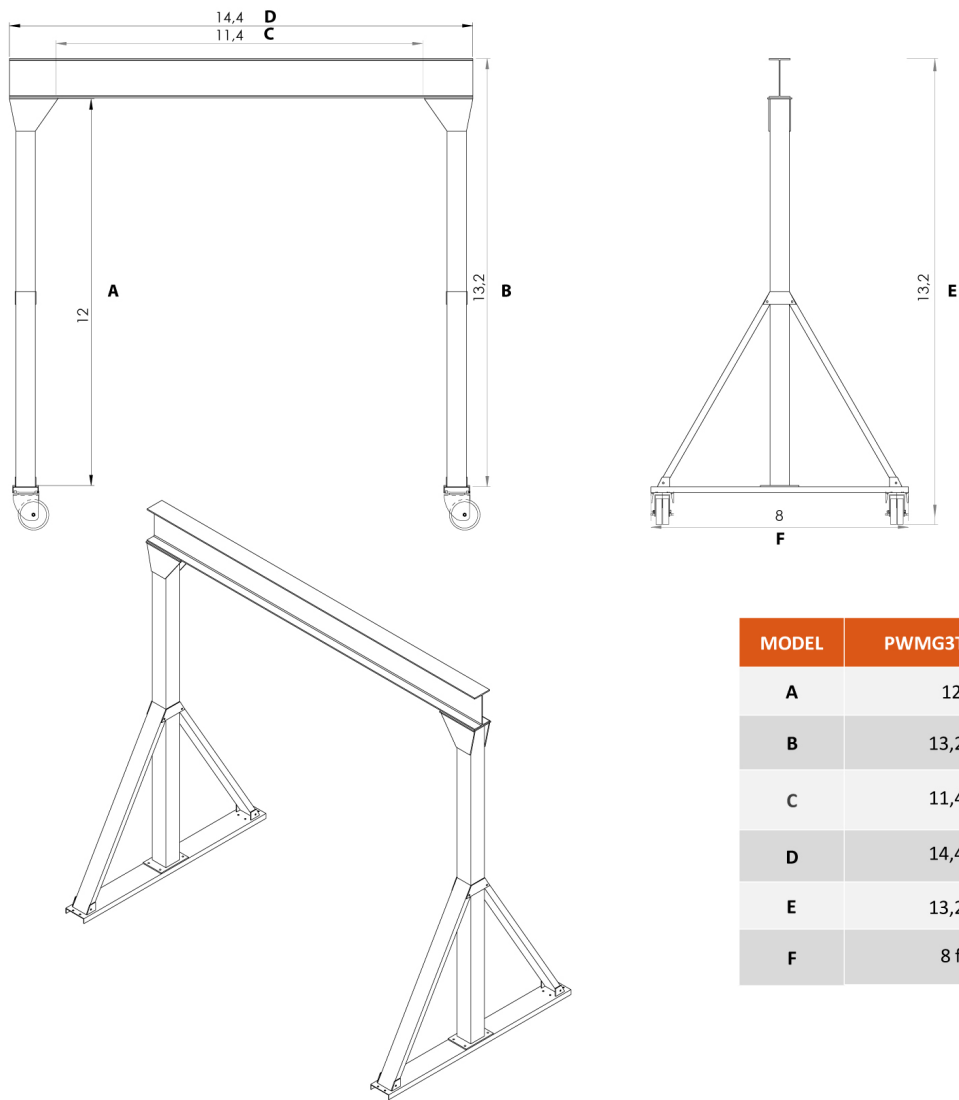

MODEL	PWMG3T-S12-H12
A	12 ft
B	13,2 ft
C	11,4 ft
D	14,4 ft
E	13,2 ft
F	8 ft

Unit Weight & Dimensions

Total Unit Weight	968 lbs / 440 Kg
--------------------------	------------------

Packaging Weight & Dimensions

Package 1 Net Weight	968 lbs / 439 Kg
-----------------------------	------------------

Package 1 Width	145 in / 368.3 cm
------------------------	-------------------

Package 1 Gross Weight	1162 lbs / 527 Kg
-------------------------------	-------------------

Package 1 Height	23 in / 58.42 cm
-------------------------	------------------

Package 1 Length	39 in / 99.06 cm
-------------------------	------------------