



## 2 Ton Adjustable Telescoping Gantry Crane 11~15 ft Height 12 ft Span **MADE IN USA**

### Key features

- Load Capacity: Supports up to 2 tons, ideal for a variety of heavy lifting tasks.
- Durable Construction: Built with high-quality materials for stability and long-lasting performance.
- User-Friendly Design: Manual operation allows for straightforward lifting and lowering of loads.
- Super-strong swivel casters (all locking) with rubber for smooth rolling
- 3 Year Warranty, Customer Support and Service in the USA

### Manual Gantry Crane Description

The Manual Gantry Crane is a versatile and robust lifting solution designed to support loads of up to 2 tons. With an adjustable height range of 11 to 15 feet and a 12-foot span, this crane is perfect for various industrial and workshop applications. Proudly made in the USA, it features high-quality construction, ensuring reliability and performance in material handling tasks.

### Technical Specifications

<b>Rated Load Capacity</b>	2 ton	<b>Material</b>	Steel
<b>I-Beam Height</b>	8 in	<b>Design Factor</b>	4:1
<b>Overall SPAN</b>	12 ft	<b>I-Beam Width Range</b>	5.2 in
<b>Clear SPAN</b>	10 ft	<b>Made in</b>	USA
<b>HUB Height Under The Beam</b>	11 to 15 ft	<b>Warranty</b>	3 Year

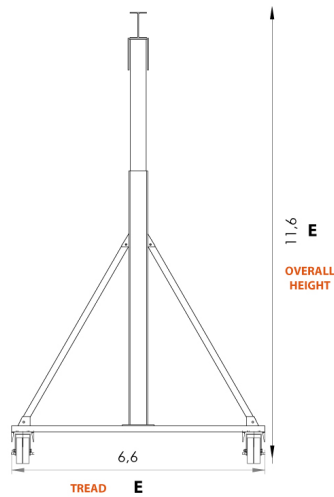
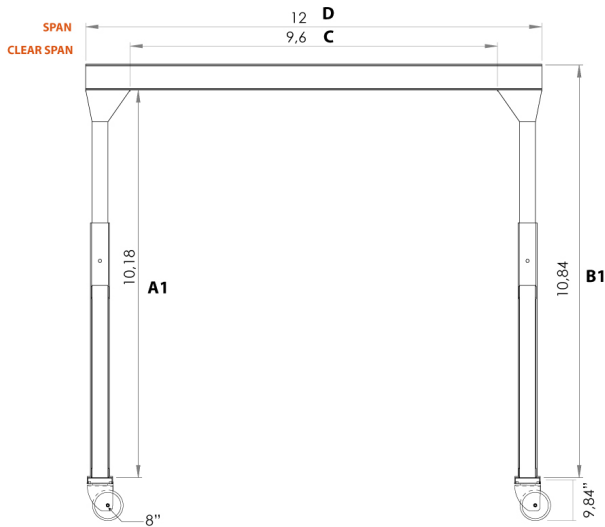

MODEL	PWMG2T-S12-H11-15a
A1	10,18 ft
B1	10,84 ft
C	9,6 ft
D	12 ft
E	11,6 ft
A2	11,6 ft
B2	14,84 ft
F	15,66 ft

