



2 Ton Fixed Height Steel Gantry Crane 11 ft Height 12 ft Span MADE IN USA

Key features

- Load Capacity: Supports up to 2 tons, suitable for a variety of heavy lifting tasks.
- Height: Fixed at 11 feet, providing ample clearance for lifting operations.
- Durable Construction: Made from high-quality materials for stability and long-lasting use.
- Super-strong swivel casters (all locking) with rubber for smooth rolling
- 3 Year Warranty, Customer Support and Service in the USA

Manual Gantry Crane 2 Ton Description

The Manual Gantry Crane is a heavy-duty lifting solution designed to support loads of up to 2 tons. With a fixed height of 11 feet and a span of 12 feet, this crane is ideal for a wide range of industrial and workshop applications. Proudly made in the USA, it features robust construction, ensuring reliability and performance in material handling tasks.

Technical Specifications

Rated Load Capacity	2 ton	Material	Steel
I-Beam Height	8 in	Design Factor	4:1
Overall SPAN	12 ft	I-Beam Width Range	5.2 in
Clear SPAN	10 ft	Made in	USA
HUB Height Under The Beam	10 ft	Warranty	3 Year

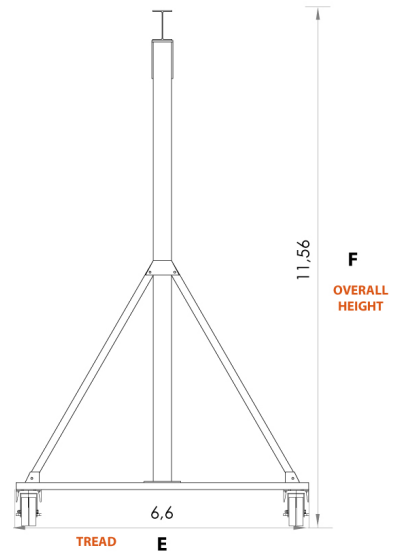
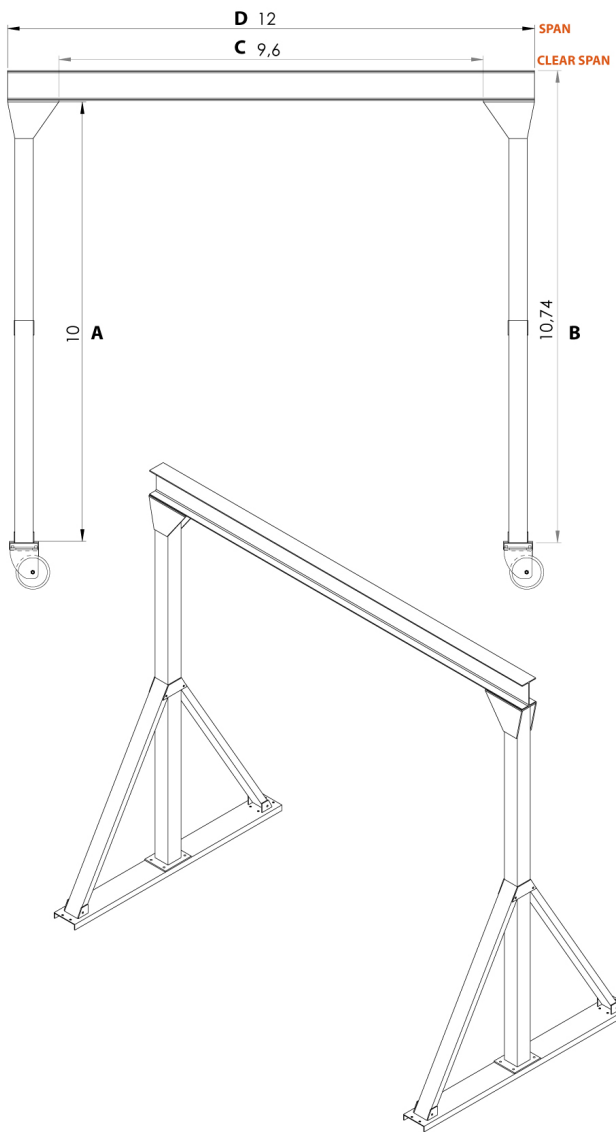

MODEL	PWMG2T-S12-H11
A	10 ft
B	10,74 ft
C	9,83
D	12 ft
E	6,6 ft
F	11,56 ft

Dimensions in ft

Unit Weight & Dimensions

Total Unit Weight	674 lbs / 306 Kg
--------------------------	------------------

Packaging Weight & Dimensions

Package 1 Net Weight	674 lbs / 306 Kg
-----------------------------	------------------

Package 1 Width	145 in / 368.3 cm
------------------------	-------------------

Package 1 Gross Weight	815 lbs / 370 Kg
-------------------------------	------------------

Package 1 Height	23 in / 58.42 cm
-------------------------	------------------

Package 1 Length	31 in / 78.74 cm
-------------------------	------------------