



## 1 Ton Adjustable Telescoping Gantry Crane 10~14 ft Height 8 ft Span **MADE IN USA**

### Key features

- Load Capacity: Supports up to 1 ton, perfect for a variety of lifting tasks.
- Durable Construction: Built with high-quality materials to ensure stability and long-lasting performance.
- Span: 8-foot width for effective load positioning and maneuverability.
- Super-strong swivel casters (all locking) with rubber for smooth rolling
- 3 Year Warranty, Customer Support and Service in the USA

### 1 Ton Adjustable Telescoping Gantry Crane Description

The Manual Gantry Crane is a versatile lifting solution designed to support loads of up to 1 ton. With an adjustable height range of 10 to 14 feet and an 8-foot span, this crane is ideal for various industrial and workshop applications. Proudly made in the USA, it combines high-quality construction with user-friendly features for efficient material handling.

### Technical Specifications

Rated Load Capacity	1 ton	Material	Steel
I-Beam Height	6 in	Design Factor	4:1
Overall SPAN	8 ft	I-Beam Width Range	4 in
Clear SPAN	6 ft	Made in	USA
HUB Height Under The Beam	10 to 13 ft	Warranty	3 Year

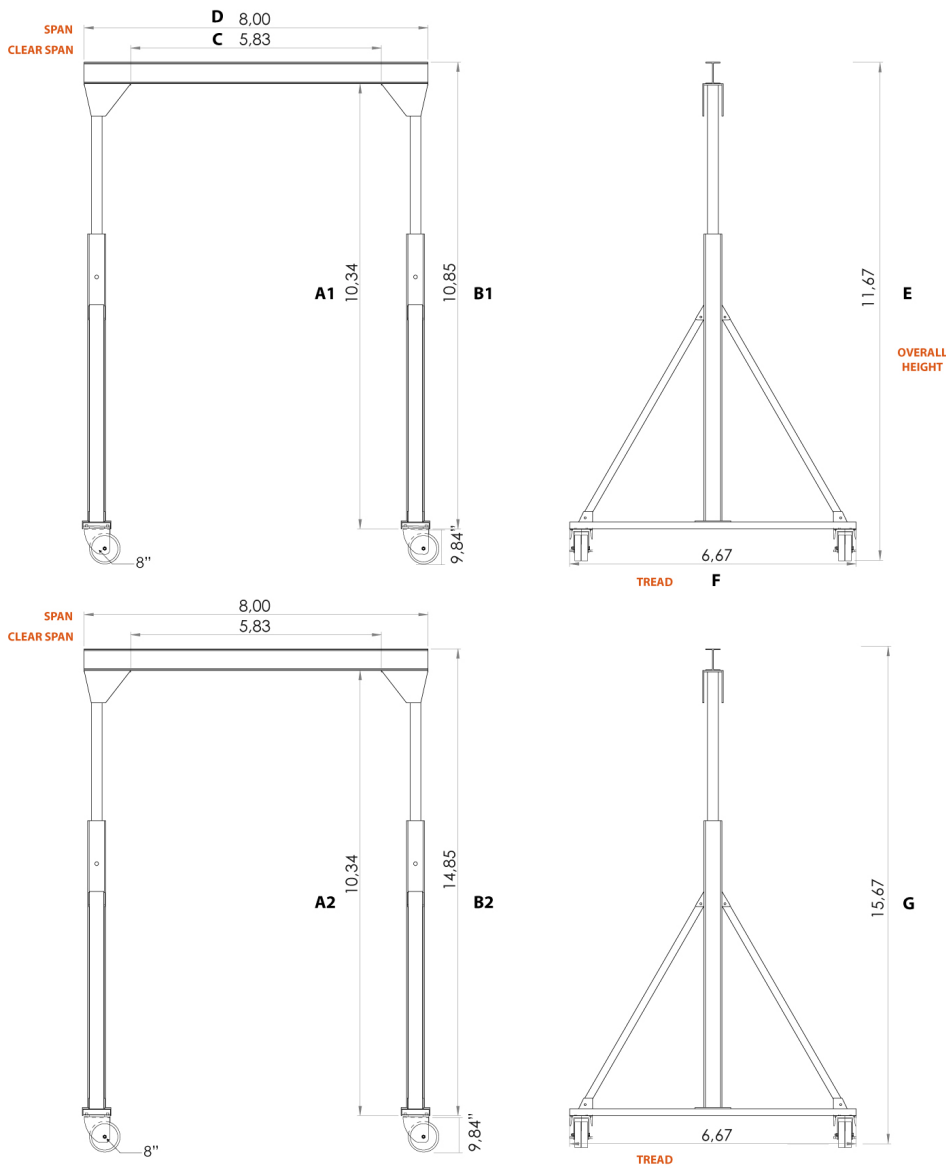

MODEL	PWMG1T-S8-H10-14a
A1	10,34 ft
B2	10,85 ft
C	8,0 ft
D	5,83 ft
E	11,67 ft
F	6,67 ft
A2	10,34 ft
B2	14,85 ft
G	15,67 ft

