



1 Ton Fixed Height Steel Gantry Crane 11 ft Height 12 ft Span MADE IN USA

Key features

- Load Capacity: Supports up to 1 ton, ideal for a variety of lifting tasks.
- Height: Fixed height of 11 feet, providing ample clearance for diverse applications.
- Durable Construction: Made with high-quality materials for stability and long-lasting performance.
- Super-strong swivel casters (all locking) with rubber for smooth rolling
- 3 Year Warranty, Customer Support and Service in the USA

Fixed Height Steel Gantry Crane Description

The Manual Gantry Crane is a reliable lifting solution designed to support loads of up to 1 ton. With a height of 11 feet and a span of 12 feet, this crane is perfect for various industrial and workshop applications. Proudly made in the USA, it combines quality construction with user-friendly operation, making it an essential tool for material handling tasks.

Technical Specifications

Rated Load Capacity	1 ton	Material	Steel
I-Beam Height	6 in	Design Factor	4:1
Overall SPAN	12 ft	I-Beam Width Range	4 in
Clear SPAN	10 ft	Made in	USA
HUB Height Under The Beam	10 ft	Warranty	3 Year

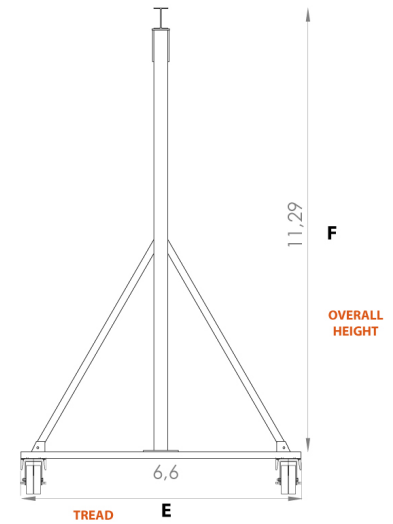
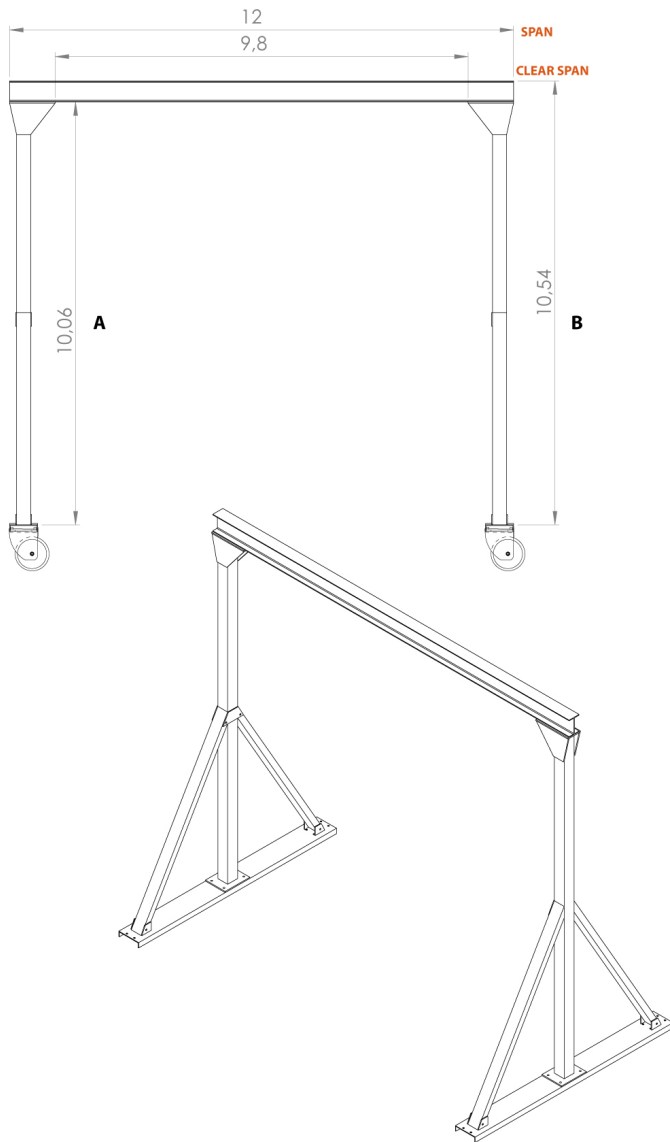

MODEL	PWMG1T-S12-H11
A	10,06 ft
B	10,54 ft
C	9,83
D	12 ft
E	6,6 ft
E	11,29

Dimensions in ft

Unit Weight & Dimensions

Total Unit Weight	529 lbs / 241 Kg
--------------------------	------------------

Packaging Weight & Dimensions

Package 1 Net Weight	529 lbs / 240 Kg
-----------------------------	------------------

Package 1 Width	145 in / 368.3 cm
------------------------	-------------------

Package 1 Gross Weight	639 lbs / 290 Kg
-------------------------------	------------------

Package 1 Height	23 in / 58.42 cm
-------------------------	------------------

Package 1 Length	31 in / 78.74 cm
-------------------------	------------------