

Hook block with pulley for PWMD3T24M

Key features

- **Compatibility:** Specifically designed for the PWMD3T24M hoist, ensuring a perfect fit and optimal performance.
- **Durable Construction:** Made from high-quality materials, the hook block is built to withstand heavy-duty use and resist wear over time.
- **Smooth Operation:** The integrated pulley allows for seamless lifting and lowering of loads, enhancing efficiency during operations.

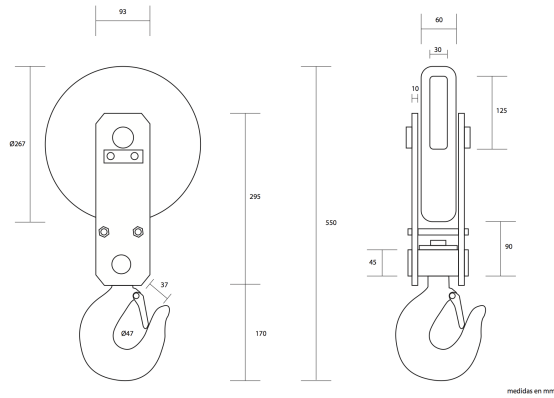

Hook block with pulley for PWMD3T24M Description

The Hook Block with Pulley for PWMD3T24M is designed to enhance the functionality and efficiency of your lifting operations. This robust hook block features a durable pulley system that provides smooth operation and reliable load management. Ideal for use in various industrial and construction applications, it ensures safe and effective handling of heavy loads.

Technical Specifications

Unit Weight & Dimensions

Total Unit Weight	48 lbs / 22 Kg
--------------------------	----------------

Packaging Weight & Dimensions

Package 1 Net Weight	48 lbs / 22 Kg
-----------------------------	----------------

Package 1 Width	15 in / 38.1 cm
------------------------	-----------------

Package 1 Gross Weight	55 lbs / 25 Kg
-------------------------------	----------------

Package 1 Height	7 in / 17.78 cm
-------------------------	-----------------

Package 1 Length	27 in / 68.58 cm
-------------------------	------------------