



1 ton 2204 lb Electric Wire Rope Hoist 24 mts. 4 ways 2 Speed H3 Duty Wireless

Key features

- Load Capacity: 1 ton (2204 lbs), suitable for lighter lifting tasks.
- Lifting Height: 24 meters (approximately 79 feet), accommodating high-lift requirements.
- Speed: 2 Speed settings for precise control and flexibility.
- 3 Year Warranty, Customer Support and Service in the USA

Electric Wire Rope Hoist Description

1 Ton Wireless Electric Wire Rope Hoists are used for raising and lowering material. Power Cord is standard at 3 ft. for Hook and Push Trolley Mounts. Power Cord is standard at 3 ft. for Motorized Trolley Mounts. Hoists usually ship within 1-3 business days after ordering. Please call us at 1 (800) 971-8061 for any special requests. The Highest Quality, most Technologically Advanced Hoist in the Industry. Our hoist ranges from basic Light Duty H1 to Heavy Duty Motor - 60 minute, H4 classification, Class B insulation with cooling fins and standard thermal motor protection. Compact lightweight body offers one of the lowest headroom hoists in the industry. Extremely durable and reliable Pull Rotor Motor Brake. Contains NO brake coil to fail like conventional disc brakes. Durable Push-Button Pendant for easy, one-handed operation. (Now with an included professional Industrial wireless remote control kit). Double speed functionality allows for a precise maneuverability and precision. Includes strain relief wire molded to pendant cord for added support and reliability. Easy Maintenance Control Panel is hinged to swing out to provide fast, easy, and trouble-free access. Completely Sealed Body suitable for both indoor and outdoor applications, including harsh environments. Gaskets throughout the hoist provide an IP55 rating. Oil Bath and precision machined helical and spur gears provide for quiet, smooth, and cool operations.

Technical Specifications

Rated Load Capacity	2204 lb / 1000 kg	Control	Pendant Control and Optional Wireless F21
Standard Lifting Height	80 ft / 24 m	Control Voltage	24 V
Speed (f/m) / min	3-26 ft / 0.8-8 m	Contactors	Schneider or EATON
Number of Speeds	2 Speed	Wire Rope	ø9/16 in x 79 ft ø13 mm x 48 m
Voltage	3 Phase 208~240/440~480V 50/60Hz	Humidity	<85%
Available Voltages	460V-US / 380V-CHILE	Temperature	-4°~104° F / -20°~40° C
Duty Class	H3/M4/1Am/Class C	Trolley Power	0.8-4.5 kW 3 Ph
Motor Type (68)	Squirrel Cage Induction Motor	Noise Level	82 dB
Motor Power (6)	0.4-3 kW	Trolley Speed /min	66 ft / 20 m
Motor RPM	1728@60Hz 1440@50HZ	I-Beam Width Range	100~134 mm [3.9~5.3 in]
Insulation Grade	F	Minimum Turn Radius	13 ft / 4 m
IEC Motor Protection	IP55	Standards Compliance	ASME HST-4 , ASME B30.16 , B30.17 , EN14492-2 , EN60204-32
Dynamic Brake	Optional with VFD Driver	Warranty	3 Year

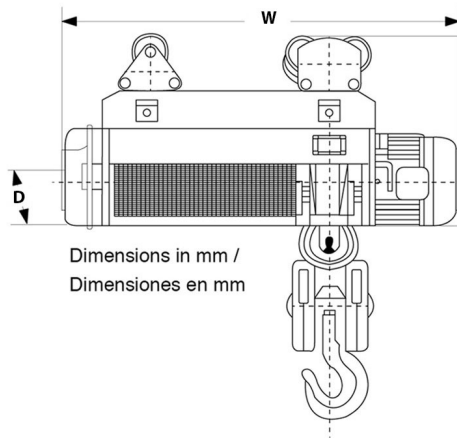

Unit Weight & Dimensions

D Depth	24 in / 600 mm
W Width	57 in / 1450 mm
Total Unit Weight	418 lbs / 190 Kg

Packaging Weight & Dimensions

Package 1 Net Weight	418 lbs / 190 Kg
Package 1 Width	17 in / 43.18 cm
Package 1 Gross Weight	448 lbs / 203 Kg
Package 1 Height	25 in / 63.5 cm
Package 1 Length	58 in / 147.32 cm