

10 ton 22000 lb Electric Wire Rope Hoist 24 mts. 4 ways 2 Speed H3 Duty Wireless



Key features

- Load Capacity: 10 tons (22,000 lbs) for heavy lifting needs.
- Lifting Height: 24 meters (approximately 79 feet) for extensive reach.
- Speed: 2 Speed settings for adjustable lifting speed.
- 3 Year Warranty, Customer Support and Service in the USA

Electric Wire Rope Hoist Description

10 Ton Wireless Electric Wire Rope Hoists are used for raising and lowering material. Power Cord is standard at 3 ft. for Hook and Push Trolley Mounts. Power Cord is standard at 3 ft. for Motorized Trolley Mounts. Hoists usually ship within 1-3 business days after ordering. Please call us at 1 (800) 971-8061 for any special requests. The Highest Quality, most Technologically Advanced Hoist in the Industry. Our hoist ranges from basic Light Duty H1 to Heavy Duty Motor - 60 minute, H4 classification, Class B insulation with cooling fins and standard thermal motor protection. Compact lightweight body offers one of the lowest headroom hoists in the industry. Extremely durable and reliable Pull Rotor Motor Brake. Contains NO brake coil to fail like conventional disc brakes. Durable Push-Button Pendant for easy, one-handed operation. (Now with an included professional Industrial wireless remote control kit). Double speed functionality allows for a precise maneuverability and precision. Includes strain relief wire molded to pendant cord for added support and reliability. Easy Maintenance Control Panel is hinged to swing out to provide fast, easy, and trouble-free access. Completely Sealed Body suitable for both indoor and outdoor applications, including harsh environments. Gaskets throughout the hoist provide an IP55 rating. Oil Bath and precision machined helical and spur gears provide for quiet, smooth, and cool operations.

Technical Specifications

Rated Load Capacity	22000 lb / 10000 kg	Control	Pendant Control and Optional Wireless F21
Standard Lifting Height	80 ft / 24 m	Control Voltage	24 V
Speed (f/m) / min	3-26 ft / 0.8-8 m	Contactors	Schneider or EATON
Number of Speeds	2 Speed	Humidity	<85%
Voltage	3 Phase 208~240/440~480V 50/60Hz	Temperature	-4°~104° F / -20°~40° C
Available Voltages	460V-US / 380V-CHILE	Trolley Power	0.8 kW 3 Ph
Duty Class	H3/M4/1Am/Class C	Noise Level	82 dB
Motor Type (68)	Squirrel Cage Induction Motor	Trolley Speed /min	66 ft / 20 m
Motor Power (6)	1.5-13 kW 3Ph	I-Beam Width Range	138~180 mm [5.4~7.1 in]
Motor RPM	1728@60Hz 1440@50HZ	Minimum Turn Radius	25 ft / 7.5 m
Insulation Grade	F	Standards Compliance	ASME HST-4 , ASME B30.16 , B30.17 , EN14492-2 , EN60204-32
IEC Motor Protection	IP55	Warranty	3 Year
Dynamic Brake	Optional with VFD Driver		

FRONT VIEW / VISTA FRONTAL

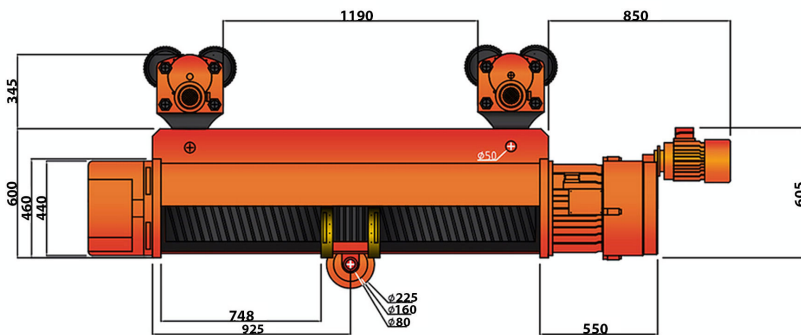

LATERAL VIEW / VISTA LATERAL

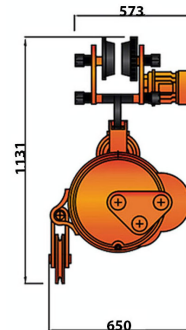

BACK VIEW / VISTA TRASERA

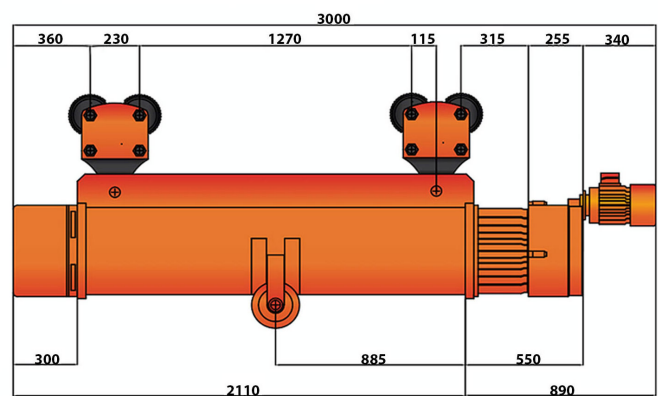

SIDE VIEW / VISTA SUPERIOR

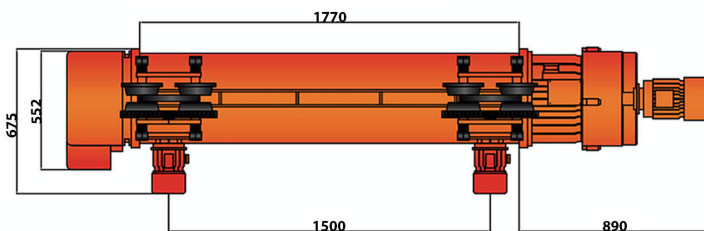

Dimensions in mm / Dimensiones en mm
Tolerancia ± 2mm



Service/Servicio	Load/Carga	Time/Tiempo	Maintenance/ Mantenimiento
Normal	< 65%	< 25%	6~12 (months/meses)
Heavy/Pesado	> 65%	> 25%	3~6 (months/meses)
Severe/Severo	Abnormal Conditions En Condiciones Anormales Environmental, Geographical & Risky Ambientales, Geograficas & Riesgosas	<Duty cycle limit <Limite ciclo de trabajo	1~3 (months/meses)

Unit Weight & Dimensions

Total Unit Weight 2426 lbs / 1101 Kg

Packaging Weight & Dimensions

Package 1 Net Weight 2426 lbs / 1101 Kg

Package 1 Width 29 in / 73.66 cm

Package 1 Gross Weight 2456 lbs / 1114 Kg

Package 1 Height 34 in / 86.36 cm

Package 1 Length 112 in / 284.48 cm