

## 440 lbs Heavy Duty Electric Winch Wire Rope 110/120V

### Key features

- Capacity: Handles up to 440 lbs, suitable for lighter to moderate lifting and pulling tasks.
- Power Supply: Operates on 110/120V, compatible with standard residential and commercial electrical systems.
- Heavy-Duty Construction: Designed with durable materials to ensure reliability and withstand demanding conditions.
- 1 Year Warranty, Customer Support and Service in the USA



### Winch Description

This durable electric winch offers a 440 lb lifting capacity and operates on a 110/120V power supply. Equipped with a sturdy wire rope, it is designed for reliable performance in light to medium-duty applications. Ideal for various tasks, this winch provides efficient and dependable lifting and pulling capabilities.

### Prowinch Compact Winch

All of our compact winches are created with the goal of offering the best price-performance ratio. Key components such as lifespan factors are constantly tested and improved in order to offer the best product for the price.

### Key Components

All internal components have been upgraded to meet the highest quality standards. Key electronic components are produced by American or German brands, and we use American-made lubricants to ensure the lifespan of gears and reducers. Final assembly and all tests are performed locally at Prowinch facility before shipping to ensure that every unit meets the corresponding standard.

### Duty Classification

Duty Classification is a key factor when choosing the right unit. This H4 heavy duty industrial winch is suitable for high-volume handling in mining, construction, forestry, manufacturing plants and mills, and foundries. For uniformly distributed work periods, the winches have 50% max. operational time per hour and can handle up to 300 starts per hour. When being used for infrequent work periods, the winch can be operated for 30 minutes from a cold start with up to 300 starts per hour. Operational time ratings are calculated at a 65% load factor, as per ASME Standard.

### Control System

For this winch we offer different control options: single speed IP66 control with up, down, and emergency stop, a variable speed control with a dynamic brake and an SEW Eurodrive German Driver or Lenze USA Driver, wireless remote controls, or a PWZR series full desktop control with Touch Screen controls and indicators, overload protection, and alarms to give the operator all the necessary information for a safe operation of the winch and much more. The winch contains the best electric components available on the market and is made, assembled and tested by Prowinch locally in the US, Chile, or Colombia.

### Braking System

Prowinch compact winches includes two brakes, one reducer brake and one motor brake. For additional safety we also offer an optional drum brake and dynamic brake. All brake systems are tested at 125% of the rated winch capacity and are designed to automatically engage immediately upon any loss of power.

## Technical Specifications

<b>1st Layer Rated Capacity</b>	440 lb / 200 kg	<b>Control Voltage</b>	110V
<b>Speed (f/m) / min</b>	36~49 ft / 11~15 m	<b>Transmission / Reducer Type</b>	Planetary Reducer
<b>Number of Speeds</b>	1 Speed	<b>Drum Brake</b>	NO
<b>Voltage</b>	1 Phase 110~120V 60Hz	<b>Free Spooling Clutch Type</b>	NO
<b>Motor Type (68)</b>	Electric AC	<b>Wire Rope</b>	ø1/4 in x 98 ft   ø6.3 mm x 30 m
<b>IEC Motor Protection</b>	IP55	<b>Standards Compliance</b>	ASME B30.7
<b>IEC Electric Control Box Protection</b>	IP65	<b>Warranty</b>	1 Year
<b>Control</b>	Wired remote control	<b>Standard Lifting Height</b>	100 ft / 30 m

<b>INCLUDED / INCLUIDO</b>	<b>RR-W-410E 7 / 6x19/6x26 EIPS Fiber Core/ Alma de Fibra</b>			
	<b>Rope Diameter / Diámetro del Cable:</b>		1/4 in   6.3 mm	
	<b>Nominal Strength / Resistencia Nominal:</b>		6.01 lb / 2.73 kg	
	<b>Rope Weight x ft / Peso del cable x m:</b>		0.10 lb / 0.1 kg	
	<b>Layer / Capa</b>	<b>Rope on drum / Mts x Capa</b>	<b>Lifting x layer / Cap x Capa</b>	<b>Speed / Velocidad (per/min)</b>
	1	21 ft / 7 m	441 lb / 200 kg	38.3 ft / 11.7 m
2	45 ft / 14 m	394 lb / 179 kg	42.8 ft / 13 m	
3	72 ft / 22 m	357 lb / 162 kg	47.3 ft / 14.4 m	
4	101 ft / 31 m	325 lb / 148 kg	51.8 ft / 15.8 m	

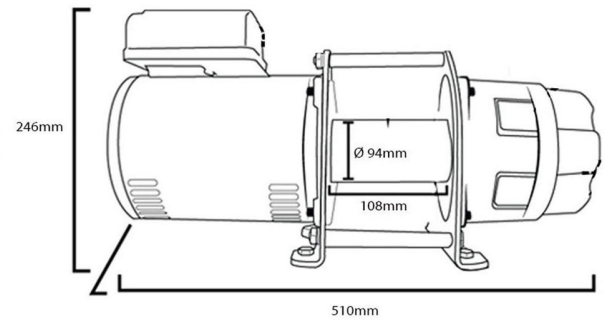

Referential Images  
Specifications may change without notice

## Unit Weight & Dimensions

<b>A Total Height</b>	246 mm	<b>Package 1 Net Weight</b>	79 lbs / 36 Kg
<b>Drum FD Flange Diameter (57)</b>	ø7 mm	<b>Package 1 Width</b>	22 in / 55.88 cm
<b>W Width</b>	510 mm	<b>Package 1 Gross Weight</b>	83 lbs / 38 Kg
<b>Drum DL Length (56)</b>	94 mm	<b>Package 1 Height</b>	12 in / 30.48 cm
<b>Drum BD Barrel Diameter (58)</b>	ø94 mm	<b>Package 1 Length</b>	12 in / 30.48 cm
<b>Total Unit Weight</b>	79 lbs / 36 Kg		

## Packaging Weight & Dimensions