



800 lb 110V 1 Speed Mini Electric Chain Hoist Power Trolley 20 ft. Chain H3 Duty

Key features

- Load Capacity: 800 lbs, designed for lighter lifting tasks.
- Voltage: 110V, suitable for standard residential and commercial electrical systems.
- Speed Settings: 1 speed, providing straightforward operation.
- 3 Year Warranty, Customer Support and Service in the USA

Electric Chain Hoist Description

This 800 lb mini electric chain hoist is designed for reliable and efficient lifting in various industrial and workshop settings. Operating on a 110V power supply, it features a single-speed motor that ensures smooth and consistent performance. With a 20 ft. chain, it provides sufficient reach for a variety of lifting tasks, while its H3 duty rating indicates suitability for medium-duty applications. The integrated power trolley allows for effortless movement along beams, enhancing maneuverability and operational flexibility. Ideal for use in workshops, assembly lines, and warehouses, this hoist offers dependable performance and durability for your lifting requirements.

Prowinch Electric Chain Hoist

All of our **Electric Chain Hoists** are created with the goal of offering the best price-performance ratio. Key components such as lifespan factors are constantly tested and improved in order to offer the best product for the price.

Key Components

All internal components have been upgraded to meet the highest quality standards. Key electronic components are produced by American or German brands, and we use American-made lubricants to ensure the lifespan of gears and reducers. Final assembly and all tests are performed in the US before shipping to ensure that every unit meets the corresponding standard.

Duty Classification

Duty classification is a key factor when choosing the right unit. These H3 hoists are suitable for general machine shop fabricating, assembly, storage, and warehousing. For uniformly distributed work periods, the hoists have 25% max. operational time per hour and can handle up to 150 starts per hour. When being used for infrequent work periods, the hoist can be operated for 30 minutes from a cold start with up to 200 starts per hour. Operational time ratings are calculated at a 65% load factor, as per ASME HST-1-2012.

Control System

This **Electric Chain Hoist** comes with a pendant control with up, down, and emergency stop. The length of the pendant control is 4 feet less than the lifting height, which allows it to be easily operated from ground-level.

Braking System

The **electromagnetic brake system** is tested at 125% of the hoist capacity and is designed to automatically engage immediately upon any loss of power.

Technical Specifications

Rated Load Capacity	800 lbs / 360 kg	Control Voltage	24V
Standard Lifting Height	15 ft / 4.5 m	Emergency Stop	Yes
Speed (f/m) / min	7 ft / 2.1 m	Load Chain Type	G100
Number of Speeds	1 Speed	Chain Falls	2
Voltage	1 Phase 110~120V 60Hz	Chain Length	20 ft / 6 m
USA and Canada Voltage	110~120V	Humidity	<85%
Total Power Watts	150	Temperature	-4 ~ 104° F / -20 ~ 40° C
Duty Class	H3/M4/1Am/Class C	Noise Level	81 dBf
Motor Power (6)	0.2 kw	Trolley Number of Speeds	1
Motor Brake	Yes	I-Beam Width Range	3 - 7in
Insulation Grade	F	Standards Compliance	UL 1340 - ASME HST-1 , ASME B30.16, EN60204-32
IEC Motor Protection	IP55	Warranty	3 Year
Control	Pendant Control		

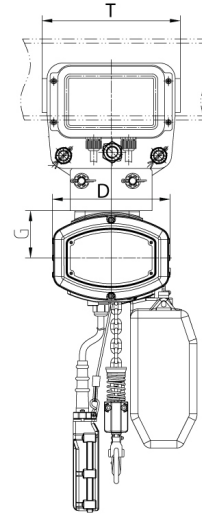
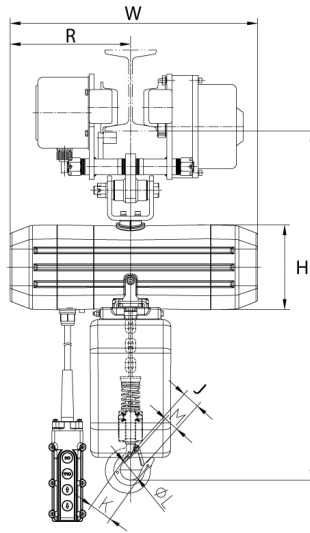

Unit Weight & Dimensions

H Minimum Headroom	16.7 in / 42.5 cm
J Hook Opening	1 in / 2.8 cm
D Depth	6 in / 15 cm
X Wheels Diameter	3.75in
W Width	14.1 in / 36 cm
Total Unit Weight	121 lbs / 55 Kg

Packaging Weight & Dimensions

Package 1 Net Weight	40 lbs / 18 Kg
Package 2 Net Weight	81 lbs / 37 Kg
Package 1 Gross Weight	62 lbs / 28 Kg
Package 2 Gross Weight	117 lbs / 53 Kg
Package 1 Length	18 in / 45.72 cm
Package 2 Length	29 in / 73.66 cm
Package 1 Width	14 in / 35.56 cm
Package 2 Width	19 in / 48.26 cm
Package 1 Height	16 in / 40.64 cm
Package 2 Height	18 in / 45.72 cm