



2 ton 4400 lb 208~240/440~480V 2 Speed Electric Chain Hoist Power Trolley 20 ft. FEC G80 Japan Chain H4 Duty Wireless

Key features

- Load Capacity: 2 tons (4,400 lbs) - robust lifting power for heavy-duty tasks.
- Voltage: 208~240/440~480V - versatile power options.
- Speed: 2-speed settings - offers flexibility for different lifting requirements.
- 3 Year Warranty, Customer Support and Service in the USA

Electric Chain Hoist Description

This 2-ton (4400 lb) electric chain hoist offers versatility with its 2-speed operation, catering to both high-speed and precise lifting needs. It operates on dual voltage options (208~240/440~480V), ensuring compatibility with various power setups. The hoist is equipped with a 20 ft FEC G80 Japan chain, built to handle demanding tasks with an H4 duty rating, suitable for heavy-duty operations. The included power trolley facilitates smooth horizontal movement, while the wireless control system enhances ease of operation and safety. Ideal for industrial applications requiring efficient and reliable lifting solutions.

Prowinch Two Speed Electric Chain Hoist with Power Trolley

All of our Electric Chain Hoists are created with the goal of offering the best price-performance ratio. Key components such as lifespan factors are constantly tested and improved in order to offer the best product for the price.

Key Components

All internal components have been upgraded to meet the highest quality standards. Key electronic components are produced by American or German brands, and we use American-made lubricants to ensure the lifespan of gears and reducers. Final assembly and all tests are performed in the US before shipping to ensure that every unit meets the corresponding standard.

Duty Classification

Duty Classification is a key factor when choosing the right unit. These H4 hoists are suitable for high-volume handling in steel warehouses, machine shops, fabricating plants and mills, and foundries. For uniformly distributed work periods, the hoists have 50% max. operational time per hour and can handle up to 300 starts per hour. When being used for infrequent work periods, the hoist can be operated for 30 minutes from a cold start with up to 300 starts per hour. Operational time ratings are calculated at a 65% load factor, as per ASME HST-1-2012.

Control System

This electric chain hoist comes standard with an industrial wireless remote control and a pendant control. The length of the pendant control is 4 feet less than the lifting height, which allows it to be easily operated from ground-level.

Braking System

The electromagnetic brake system is tested at 125% of the hoist capacity and is designed to automatically engage immediately upon any loss of power.

Technical Specifications

Rated Load Capacity	4400 lbs / 2000 kg	Control	Wireless PW-Q404 and Pendant Control
Standard Lifting Height	20 ft / 6 m	Control Voltage	24V
Speed (f/m) / min	0.8 / 2.5 m/min	Emergency Stop	Yes
Number of Speeds	2 Speed	Load Chain Type	G80 JAPAN
Voltage	3 Phase 208~240/440~480V 50/60Hz	Load Chain Size	11.2 x 34 mm
USA and Canada Voltage	208~240/440~480V	Chain Falls	1
Available Voltages	208~240/440~480V for USA and 380/440~480V for CHILE	Chain Length	20 ft / 6 m
Total Power Watts	1600	Humidity	<85%
FCC ID	2AZMK-Q1212	Temperature	-4 ~ 104° F / -20 ~ 40° C
Duty Class	H4/M5/2m/Class D	Noise Level	81 dB
Motor Power (6)	3 kW	Trolley Number of Speeds	1
Motor Brake	Yes	I-Beam Width Range	5 - 7 inches
Insulation Grade	F	Standards Compliance	UL 1340, ASME HST-1 , ASME B30.16 , B30.17, EN60204-32
IEC Motor Protection	IP55	Warranty	3 Year

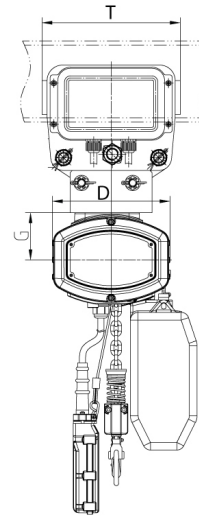
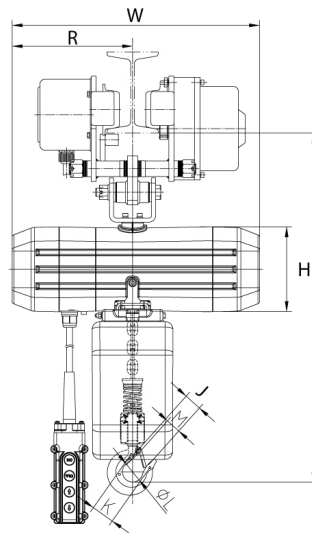

Unit Weight & Dimensions

T Trolley Motor Width	6.9 in / 16.5 cm
W Width	27.5 in / 69.4 cm
H Minimum Headroom	23 in / 57.5 cm
J Hook Opening	1.53 in / 3.9 cm
D Depth	14 in / 35 cm
Total Unit Weight	285 lbs / 130 Kg

Packaging Weight & Dimensions

Package 1 Net Weight	177 lbs / 80 Kg
Package 2 Net Weight	108 lbs / 49 Kg
Package 1 Gross Weight	221 lbs / 100 Kg
Package 2 Gross Weight	143 lbs / 65 Kg
Package 1 Length	25 in / 63.5 cm
Package 2 Length	29 in / 73.66 cm
Package 1 Width	25 in / 63.5 cm
Package 2 Width	18 in / 45.72 cm
Package 1 Height	20 in / 50.8 cm
Package 2 Height	18 in / 45.72 cm