



5 ton 11000 lb 208~240/440~480V 2 Speed Electric Chain Hoist 30 ft. FEC G80 Japan Chain H4 Duty Wireless

Key features

- Load Capacity: 5 tons (11,000 lbs), designed for heavy-duty lifting tasks.
- Voltage Range: 208~240/440~480V, adaptable to a variety of electrical systems.
- Speed Settings: 2 speeds, providing versatility for different lifting needs and precision.
- 3 Year Warranty, Customer Support and Service in the USA

Electric Chain Hoist Description

This heavy-duty 5-ton (11,000 lb) electric chain hoist is engineered for demanding lifting tasks. It features a dual voltage capability (208~240/440~480V) and a 2-speed motor, offering both high-speed and precise lifting options for versatile operations. The 30 ft FEC G80 Japan chain ensures durability and strength for reliable performance in tough environments. With an H4 duty rating, this hoist supports continuous use and high productivity. The wireless control enhances operational flexibility and safety, allowing you to manage lifting tasks from a distance with ease. Ideal for industrial settings requiring robust and efficient lifting solutions.

Technical Specifications

Rated Load Capacity	11000 lbs / 5000 kg	Control	Wireless F21-4 and Pendant Control
Standard Lifting Height	30 ft / 9 m	Control Voltage	24V
Speed (f/m) / min	1.0 / 3.0 m/min	Emergency Stop	Yes
Number of Speeds	2 Speed	Load Chain Type	G80 JAPAN
Voltage	3 Phase 208~240/440~480V 50/60Hz	Load Chain Size	11.2x34mm
Available Voltages	208~240/440~480V for USA and 380/440~480V for CHILE	Chain Falls	2
Total Power Watts	3000	Chain Length	60 ft / 18 m
FCC ID	2AZMK-Q1212	Humidity	<85%
Duty Class	H3/M4/1Am/Class C	Temperature	-4 ~ 104° F / -20 ~ 40° C
Motor Power (6)	3 KW	Noise Level	81 dB
Motor Brake	Yes	Standards Compliance	UL 1340 - ASME HST-1 , ASME B30.16, EN60204-32
Insulation Grade	F	Warranty	3 Year
IEC Motor Protection	IP55		

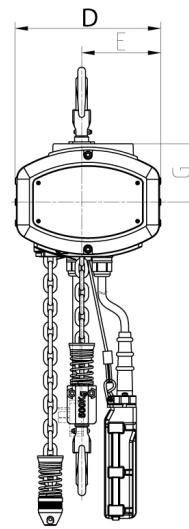
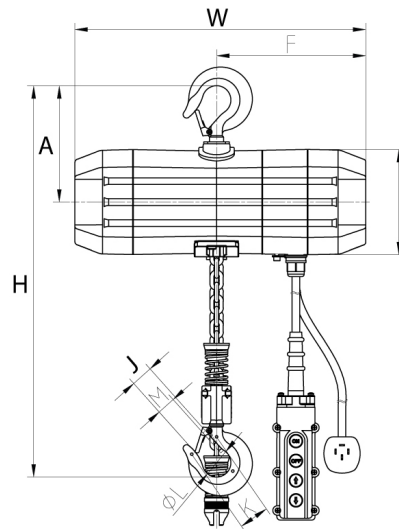

Unit Weight & Dimensions

H Minimum Headroom	34 in / 86 cm
W Width	27.5 in / 69.4 cm
D Depth	14 in / 35 cm
J Hook Opening	2.72 in / 6.9 cm
Total Unit Weight	321 lbs / 146 Kg

Packaging Weight & Dimensions

Package 1 Net Weight	321 lbs / 146 Kg
-----------------------------	------------------