



3 ton 6600 lb 208~240/440~480V 2 Speed Electric Chain Hoist 30 ft. FEC G80 Japan Chain H4 Duty Wireless

Key features

- Load Capacity: 3 tons (6600 lbs), suitable for heavy-duty lifting tasks.
- Voltage Range: 208~240/440~480V , compatible with various electrical systems.
- Speed Settings: 2 speeds, providing flexibility for different lifting requirements.
- 3 Year Warranty, Customer Support and Service in the USA

Electric Chain Hoist Description

The 3-ton (6600 lb) electric chain hoist offers versatile lifting capabilities with dual voltage options (208~240/440~480V). It features a 30 ft FEC G80 Japan chain, known for its high strength and durability. This hoist comes with a 2-speed motor, allowing precise control over lifting speeds to accommodate various operational needs. With an H4 duty rating, it is engineered for heavy-duty, continuous use in demanding environments. The wireless control system enhances operational efficiency and safety, enabling remote management of lifting tasks. Ideal for industrial applications requiring robust performance and flexibility.

Technical Specifications

Rated Load Capacity	6600 lbs / 3000 kg	Control	Wireless F21-4 and Pendant Control
Standard Lifting Height	30 ft / 9 m	Control Voltage	24V
Speed (f/m) / min	2.0 / 6.0 m/min	Emergency Stop	Yes
Number of Speeds	2 Speed	Load Chain Type	G80 JAPAN
Voltage	3 Phase 208~240/440~480V 50/60Hz	Load Chain Size	11.2x34mm
Available Voltages	208~240/440~480V for USA and 380/440~480V for CHILE	Chain Falls	1
Total Power Watts	3000	Chain Length	30 ft / 9 m
FCC ID	2AZMK-Q1212	Humidity	<85%
Duty Class	H4/M5/2m/Class D	Temperature	-4 ~ 104° F / -20 ~ 40° C
Motor Power (6)	3 KW	Noise Level	81 dB
Motor Brake	Yes	Standards Compliance	UL 1340 - ASME HST-1 , ASME B30.16, EN60204-32
Insulation Grade	F	Warranty	3 Year
IEC Motor Protection	IP55		

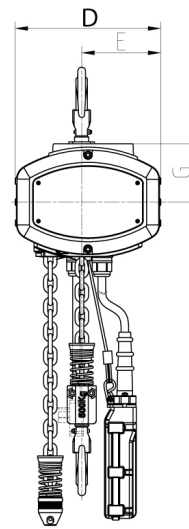
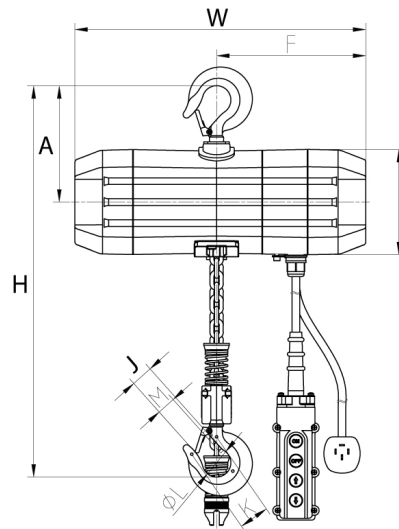

Unit Weight & Dimensions

H Minimum Headroom	23 in / 57.5 cm
W Width	27.5 in / 69.4 cm
D Depth	14 in / 35 cm
J Hook Opening	1.53 in / 3.9 cm
Total Unit Weight	273 lbs / 124 Kg

Packaging Weight & Dimensions

Package 1 Net Weight	273 lbs / 124 Kg
-----------------------------	------------------