



1/2 ton 1100 lb 2 Speed 208~240/440~480V Electric Chain Hoist 20 ft. FEC G80 Japan Chain H4 Duty Wireless

Key features

- Load Capacity: 1/2 ton (1100 lbs), ideal for handling light to moderate lifting tasks.
- Voltage Range: 208~240/440~480V, versatile for different industrial power setups.
- Operation Speed: 2 speed, providing flexibility for both high-speed lifting and precision control.
- 3 Year Warranty, Customer Support and Service in the USA

Electric Chain Hoist Description

This versatile electric chain hoist offers a lifting capacity of 1/2 ton (1100 lb) and operates efficiently on dual voltages (208~240/440~480V). Equipped with a robust 20 ft FEC G80 Japan chain, it ensures reliable performance and durability. The hoist features a 2-speed motor, providing flexibility for various lifting tasks by allowing both high-speed and precise slow-speed operations. With an H4 duty rating, it is built to withstand heavy-duty use in industrial settings. The wireless control enhances convenience and safety, enabling remote operation and efficient management of your lifting tasks. This hoist combines high performance with advanced control features for optimal productivity.

Technical Specifications

Rated Load Capacity	1100 lbs / 500 kg	Control	Wireless F21-4 and Pendant Control
Standard Lifting Height	20 ft / 6 m	Control Voltage	24V
Speed (f/m) / min	2.6 / 8 m/min	Emergency Stop	Yes
Number of Speeds	2 Speed	Load Chain Type	G80 JAPAN
Voltage	3 Phase 208~240/440~480V 50/60Hz	Load Chain Size	6.3x19mm
Available Voltages	208~240/440~480V for USA and 380/440~480V for CHILE	Chain Falls	1
Total Power Watts	900	Chain Length	20 ft / 6 m
FCC ID	2AZMK-Q1212	Humidity	<85%
Duty Class	H4/M5/2m/Class D	Temperature	-4 ~ 104° F / -20 ~ 40° C
Motor Power (6)	0.9 KW	Noise Level	81 dB
Motor Brake	Yes	Standards Compliance	UL 1340 - ASME HST-1 , ASME B30.16, EN60204-32
Insulation Grade	F	Warranty	3 Year
IEC Motor Protection	IP55		

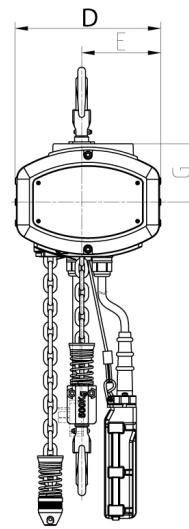
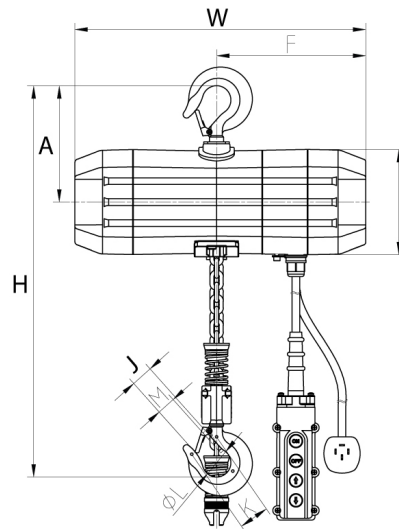

Unit Weight & Dimensions

H Minimum Headroom	17.9 in / 45.5 cm
W Width	18.1 in / 45.8 cm
D Depth	9.1 in / 22.9 cm
J Hook Opening	1.46 in / 3.7 cm
Total Unit Weight	93 lbs / 43 Kg

Packaging Weight & Dimensions

Package 1 Net Weight	93 lbs / 42 Kg
Package 1 Width	19 in / 48.26 cm
Package 1 Gross Weight	123 lbs / 56 Kg
Package 1 Height	18 in / 45.72 cm
Package 1 Length	24 in / 60.96 cm