



5 Ton Crane Scale Light Alloy IP67

Key features

- **5 Ton Capacity:** Designed to weigh loads up to 11,000 lbs, making it versatile for medium-duty industrial lifting operations.
- **Light Alloy Construction:** Built from high-strength, lightweight alloy, ensuring both durability and ease of use without adding unnecessary weight to your operations.
- **IP67 Rating:** Dustproof and waterproof, offering protection against the elements, making it ideal for outdoor and harsh industrial settings.
- **3 Year Warranty, Customer Support and Service in the USA**

5 Ton Crane Scale Light Alloy IP67 Description

The 5 Ton Crane Scale Light Alloy IP67 is a robust and reliable weighing solution for mid-range industrial applications. With a capacity of 5 tons (11,000 lbs), this crane scale is perfect for industries requiring accurate, real-time weight measurements of medium to large loads. Its lightweight alloy construction and IP67 rating make it suitable for harsh environments, offering durability and protection against dust and water ingress.

Technical Specifications

Rated Load Capacity	11000 lb / 5 ton	Minimum Weight	88 lb / 40 kg
Accuracy Grade	Grade III / n=3000	Receiver Power Supply	3 Battery (pilas) AA 1.5V
Scale Interval	1/2/5/10/20/50 lb/kg	Operating Temperature Range	4° - 122 °F / -20° - 50° C
Sample Rate (per sec)	80 times/veces	Warranty	3 Year

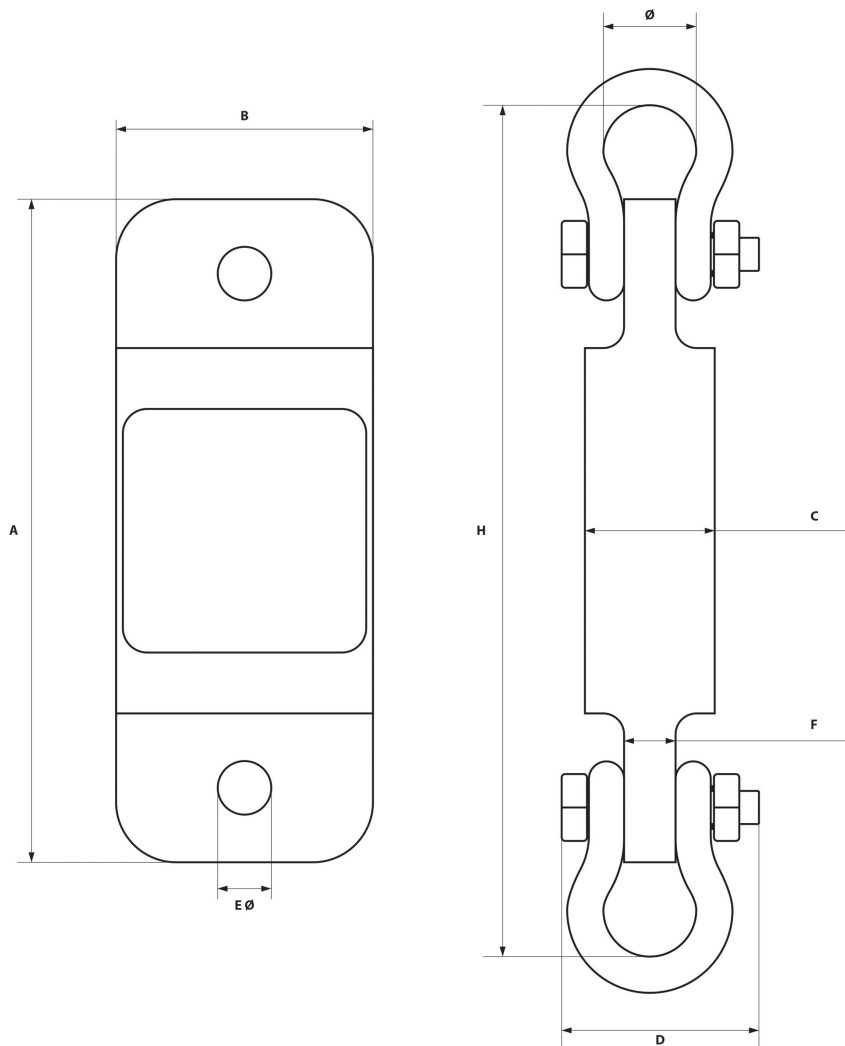

Model / Modelo	PWHYCS1T	PWHYCS5T	PWHTCS10T	PWHYCS20T	PWHYCS30T	PWHYCS50T
A	9 5/8 in	11 1/4 in	12 1/3 in	16.5 in	16.5 in	18.3 in
	244.5 mm	286 mm	318 mm	420 mm	420 mm	465 mm
B	3 3/4 in	4 in	4 1/2 in	4.8 in	5.4 in	5.9 in
	95.3 mm	102 mm	114 mm	128 mm	138 mm	150 mm
C	1 7/8 in	2 in	1 7/8 in	2.8 in	3.1 in	3.9 in
	47.6 mm	51 mm	48 mm	70 mm	80 mm	100 mm
D	2 13/16 in	4 7/8 in	6 1/2 in	10.2 in	11 in	12 in
	71.4 mm	124 mm	165 mm	260 mm	280 mm	305 mm
Ø	1 3/8 in	2 1/4 in	3 1/4 in	5 in	5.7 in	7.2 in
	34.9 mm	57 mm	83 mm	127 mm	146 mm	184 mm
H	12 in	16 in	19 1/2 in	25.9 in	29.1 in	36.6 in
	304.8 mm	406 mm	495 mm	660 mm	740 mm	930 mm
EØ	13/16 in	1 7/16 in	1 7/6 in			
	19.6 mm	37 mm	37 mm			
F	3/4 in	1 3/8 in	1 7/8 in			
	19.04 mm	35 mm	48 mm			

Unit Weight & Dimensions

Total Unit Weight	14 lbs / 7 Kg
--------------------------	---------------

Packaging Weight & Dimensions

Package 1 Net Weight	14 lbs / 6 Kg
-----------------------------	---------------

Package 1 Width	11 in / 27.94 cm
------------------------	------------------

Package 1 Gross Weight	17 lbs / 8 Kg
-------------------------------	---------------

Package 1 Height	11 in / 27.94 cm
-------------------------	------------------

Package 1 Length	15 in / 38.1 cm
-------------------------	-----------------