



50 Ton Crane Scale Light Alloy IP67

Key features

- **50 Ton Capacity:** Capable of accurately weighing loads up to 110,000 lbs, making it ideal for large industrial applications.
- **Light Alloy Construction:** Built from a strong, lightweight alloy, the scale offers high durability without compromising ease of use.
- **IP67 Rating:** Dustproof and waterproof, the scale is designed for use in extreme environments, providing protection against water and dust ingress.
- **3 Year Warranty, Customer Support and Service in the USA**

50 Ton Crane Scale Light Alloy IP67 Description

The 50 Ton Crane Scale Light Alloy IP67 is a heavy-duty, high-capacity crane scale designed to handle the toughest industrial lifting applications. With a capacity of 50 tons (110,000 lbs), this crane scale is ideal for large-scale operations in construction, shipping, manufacturing, and other heavy industries. Its lightweight alloy construction and IP67 rating ensure that it can withstand harsh conditions while delivering precise weight measurements.

Technical Specifications

Rated Load Capacity	110000 lb / 50 ton	Minimum Weight	880 lb / 400 kg
Accuracy Grade	Grade III / n=3000	Receiver Power Supply	3 Battery (pilas) AA 1.5V
Scale Interval	1/2/5/10/20/50 lb/kg	Operating Temperature Range	4° - 122 °F / -20° - 50° C
Sample Rate (per sec)	80 times/veces	Warranty	3 Year

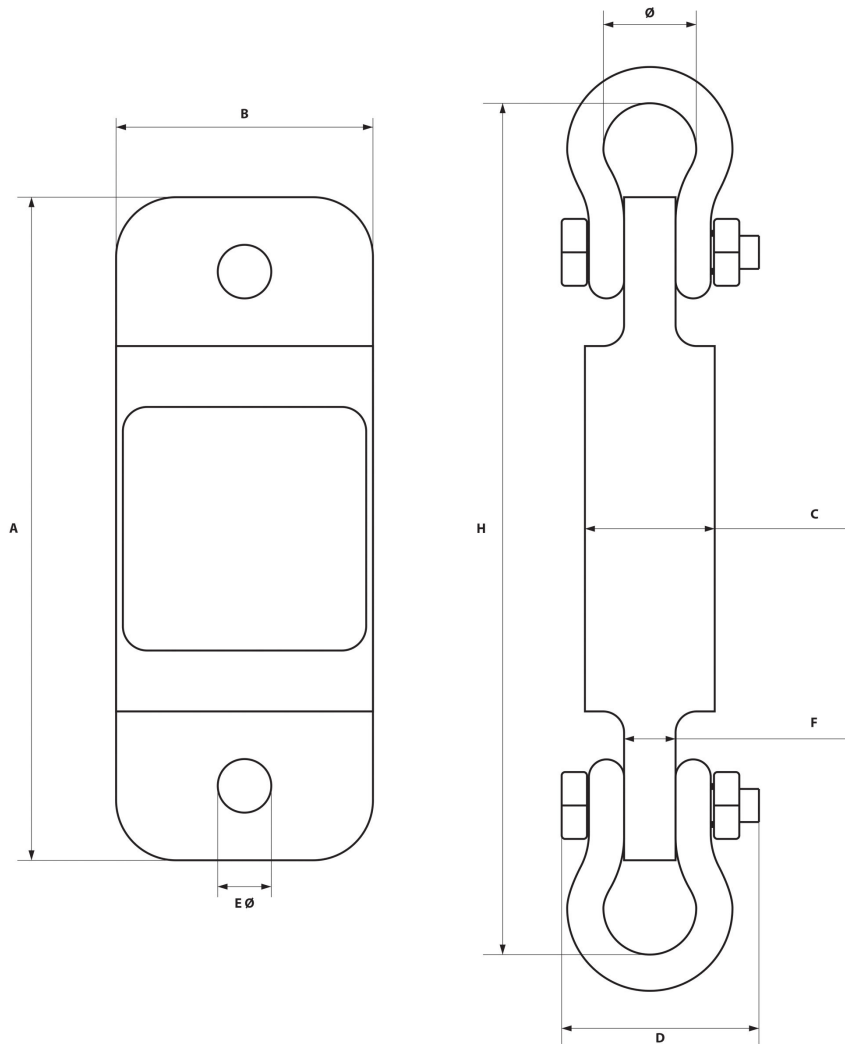

Model / Modelo	PWHYCS1T	PWHYCS5T	PWHTCS10T	PWHYCS20T	PWHYCS30T	PWHYCS50T
A	9 5/8 in 244.5 mm	11 1/4 in 286 mm	12 1/3 in 318 mm	16.5 in 420 mm	16.5 in 420 mm	18.3 in 465 mm
B	3 3/4 in 95.3 mm	4 in 102 mm	4 1/2 in 114 mm	4.8 in 128 mm	5.4 in 138 mm	5.9 in 150 mm
C	1 7/8 in 47.6 mm	2 in 51 mm	1 7/8 in 48 mm	2.8 in 70 mm	3.1 in 80 mm	3.9 in 100 mm
D	2 13/16 in 71.4 mm	4 7/8 in 124 mm	6 1/2 in 165 mm	10.2 in 260 mm	11 in 280 mm	12 in 305 mm
Ø	1 3/8 in 34.9 mm	2 1/4 in 57 mm	3 1/4 in 83 mm	5 in 127 mm	5.7 in 146 mm	7.2 in 184 mm
H	12 in 304.8 mm	16 in 406 mm	19 1/2 in 495 mm	25.9 in 660 mm	29.1 in 740 mm	36.6 in 930 mm
EØ	13/16 in 19.6 mm	1 7/16 in 37 mm	1 7/6 in 37 mm			
F	3/4 in 19.04 mm	1 3/8 in 35 mm	1 7/8 in 48 mm			

Unit Weight & Dimensions

Total Unit Weight	77 lbs / 35 Kg
--------------------------	----------------

Packaging Weight & Dimensions

Package 1 Net Weight	77 lbs / 35 Kg
-----------------------------	----------------

Package 1 Width	33 in / 83.82 cm
------------------------	------------------

Package 1 Gross Weight	92 lbs / 42 Kg
-------------------------------	----------------

Package 1 Height	17 in / 43.18 cm
-------------------------	------------------

Package 1 Length	21 in / 53.34 cm
-------------------------	------------------