



1/2 ton 1100 lb 110V 1 Speed Electric Chain Hoist 20 ft. G80 Chain H2 Duty Wireless

Key features

- High-efficiency Motor 750W 8A @ 110V. Speed 16 ft per min
- Duty Class: H2/M3/1Bm/Class B. Protection IP54
- Wired and Wireless Control. Heavy duty G80 Chain
- US and EU Standards ASME HST-1, ASME B30.16, IEC60204-32
- 3 Year Warranty, Customer Support and Service in the USA

Electric Chain Hoist Description

This **1/2 ton Electric Chain Hoist** uses a powerful motor to raise and lower loads up to 20 feet in the air. The single phase power supply makes it ideal for home or industrial applications. The hoist is easy to use which helps you complete large projects with ease.

Prowinch Electric Chain Hoist

All of our **Electric Chain Hoists** are created with the goal of offering the best price-performance ratio. Key components such as lifespan factors are constantly tested and improved in order to offer the best product for the price.

Key Components

All internal components have been upgraded to meet the highest quality standards. Key electronic components are produced by American or German brands, and we use American-made lubricants to ensure the lifespan of gears and reducers. Final assembly and all tests are performed in the US before shipping to ensure that every unit meets the corresponding standard.

Duty Classification

Duty classification is a key factor when choosing the right unit. These H2 hoists are suitable for general machine shop fabricating, assembly, storage, and warehousing. For uniformly distributed work periods, the hoists have 12.5% max. operational time per hour and can handle up to 75 starts per hour. When being used for infrequent work periods, the hoist can be operated for 15 minutes from a cold start with up to 100 starts per hour. Operational time ratings are calculated at a 65% load factor, as per ASME HST-1-2012.

Control System

This **Electric Chain Hoist** comes standard with an industrial wireless remote control and a pendant control. The length of the pendant control is 4 feet less than the lifting height, which allows it to be easily operated from ground-level.

Braking System

The **electromagnetic brake system** is tested at 125% of the hoist capacity and is designed to automatically engage immediately upon any loss of power.

Technical Specifications

Rated Load Capacity	1100 lb / 500 kg	Motor Brake	Yes
Standard Lifting Height	20 ft / 6 m	Insulation Grade	F
Speed (f/m) / min	16 ft / 5 m	IEC Motor Protection	IP54
Number of Speeds	1 Speed	Control	Wireless F21-4 and Pendant Control
Capacity Range	1	Control Voltage	24V
Voltage	1 Phase 110~120V 60Hz	Emergency Stop	Yes
USA and Canada Voltage	110~120V	Contactors	TECO 12 AMP
Available Voltages	115V 1Φ	Load Chain Type	G80
Total Power Watts	750W	Load Chain Size	8x24 mm
FCC ID	OFNF21	Chain Falls	1
Buttons	Up, Down Emergency Stop	Chain Length	20 ft / 6 m
Receiver Power Supply	24V	Humidity	<85%
Control Distance	300 ft	Temperature	-4 ~ 104° F / -20 ~ 40° C
Duty Class	H2/M3/1Bm/Class B	Noise Level	70 dB
Motor/Engine Power	0.75 kW	Standards Compliance	ASME HST-1 , ASME B30.16 , EN14492-2 , EN60204-32
Motor AMP	8	Warranty	3 Year

PWHF500u

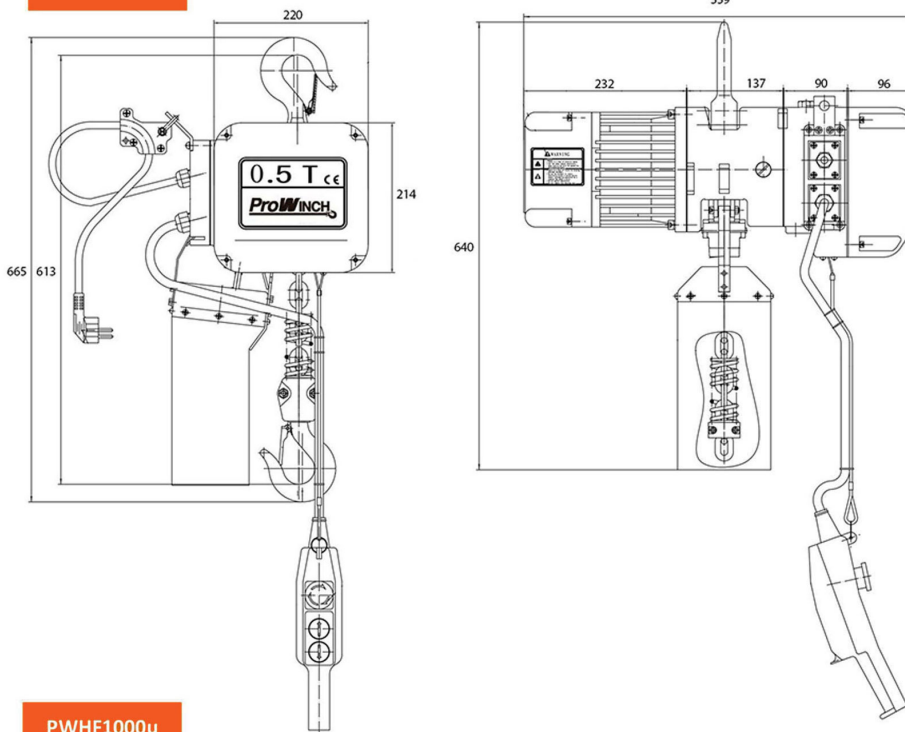

- Light die-casting aluminium housing.
- Electromagnetic Safe Brake holds load with no power.
- Upper and lower limit switches prevent over-travel
- 14ft Pendant Control with Emergency Stop switch
- Overload Protection
- Forged 360° swivel hook

PWHF1000u

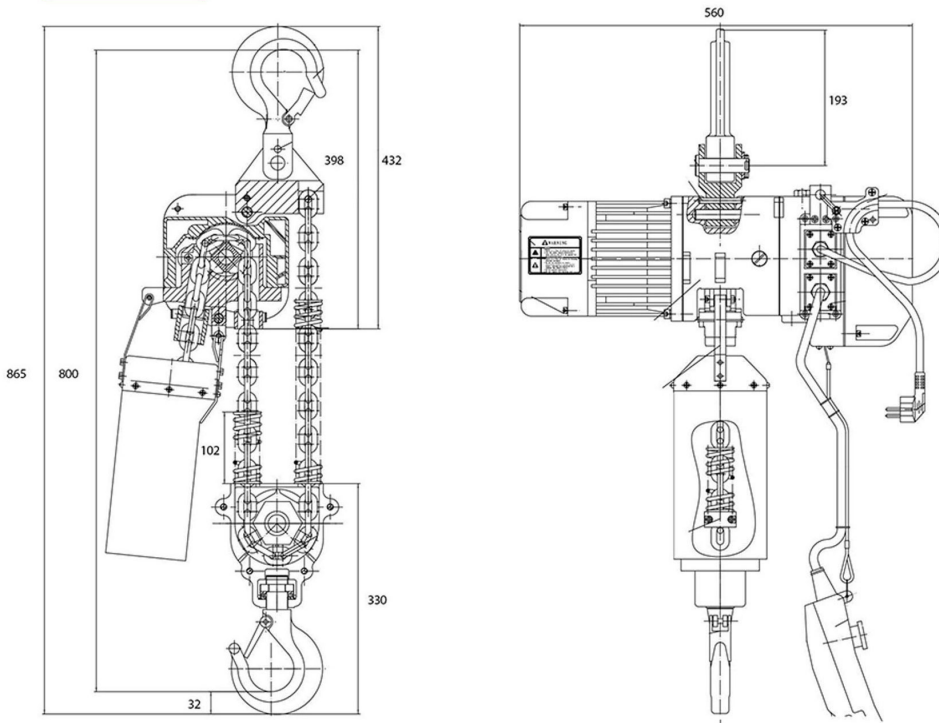

- Carcasa de aluminio fundido a presión.
- Freno de Seguridad Electromagnético que sostiene la carga sin energía. Interruptores de límite Superior e Inferior para prevenir sobrecarrera.
- Botonera de control con 4 metros e interruptor de parada de emergencia.
- Protección de sobre carga.
- Gancho Forjado de giro libre 360

Unit Weight & Dimensions

H Minimum Headroom	24 in / 613 mm
D Depth	300 mm
A Total Height	665 mm
W Width	22 in / 559 mm
Total Unit Weight	130 lbs / 59 Kg

Packaging Weight & Dimensions

Package 1 Net Weight	130 lbs / 59 Kg
Package 1 Width	15 in / 38.1 cm
Package 1 Gross Weight	130 lbs / 59 Kg
Package 1 Height	22 in / 55.88 cm
Package 1 Length	26 in / 66.04 cm