



1 ton 2200 lb 110V 1 Speed Electric Chain Hoist 20 ft. G80 Chain H2 Duty

Key features

- Load Capacity: 1 ton (2200 lbs), suitable for lifting and hoisting substantial weights.
- Voltage: 110V, ideal for applications requiring lower voltage power sources.
- Operation Speed: 1 speed, offers straightforward and dependable lifting operation.
- 3 Year Warranty, Customer Support and Service in the USA

Electric Chain Hoist Description

This electric chain hoist offers a substantial lifting capacity of 1 ton (2200 lb) and operates on 110V power. Equipped with a 20 ft G80 chain, it is built for durability and efficiency. The single-speed motor and H2 duty rating make it suitable for heavy-duty industrial applications, providing reliable and consistent performance. Designed for robustness and dependability, this hoist is ideal for demanding lifting tasks.

Prowinch Single Phase Electric Chain Hoist

All of our **Electric Chain Hoists** are created with the goal of offering the best price-performance ratio. Key components such as lifespan factors are constantly tested and improved in order to offer the best product for the price.

Key Components

All internal components have been upgraded to meet the highest quality standards. Key electronic components are produced by American or German brands, and we use American-made lubricants to ensure the lifespan of gears and reducers. Final assembly and all tests are performed in the US before shipping to ensure that every unit meets the corresponding standard.

Duty Classification

Duty classification is a key factor when choosing the right chain hoist. These H2 hoists are suitable for light machine shop fabricating, service, and maintenance. For uniformly distributed work periods, the hoists have 12.5% max. operational time per hour and can handle up to 75 starts per hour. When being used for infrequent work periods, the hoist can be operated for 15 minutes from a cold start with up to 100 starts per hour. Operational time ratings are calculated at a 65% load factor, as per ASME HST-1-2012.

Control System

This **electric chain hoist** comes standard with a pendant control. The length of the control is 4 feet less than the lifting height, which allows it to be easily operated from ground-level. An optional wireless control is available for extra convenience.

Braking System

The **electromagnetic brake system** is tested at 125% of the hoist capacity and is designed to automatically engage immediately upon any loss of power.

Technical Specifications

Rated Load Capacity	2200 lb / 1000 kg	Control Voltage	24V
Standard Lifting Height	20 ft / 6 m	Emergency Stop	Yes
Speed (f/m) / min	8 ft / 2.5 m	Contactors	TECO 12 AMP
Number of Speeds	1 Speed	Load Chain Type	G80
Voltage	1 Phase 110~120V 60Hz	Load Chain Size	8x24 mm
Available Voltages	115V 1Φ	Chain Falls	2
Total Power Watts	750W	Chain Length	40 ft / 12 m
Duty Class	H2/M3/1Bm/Class B	Humidity	<85%
Motor Power (6)	0.75 kW	Temperature	-4 ~ 104° F / -20 ~ 40° C
Motor AMP	8	Noise Level	70 dB
Motor Brake	Yes	Minimum Turn Radius	
Insulation Grade	F	Standards Compliance	ASME HST-1 , ASME B30.16 , EN14492-2 , EN60204-32
IEC Motor Protection	IP54	Warranty	3 Year
Control	Pendant Control and Optional Wireless		

PWHF500u

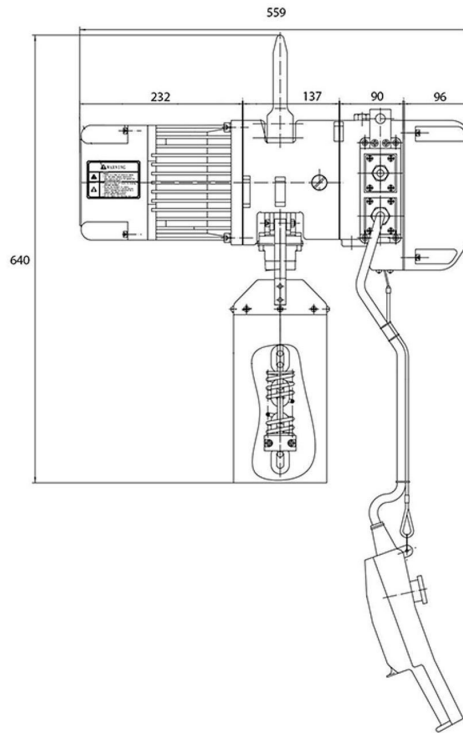
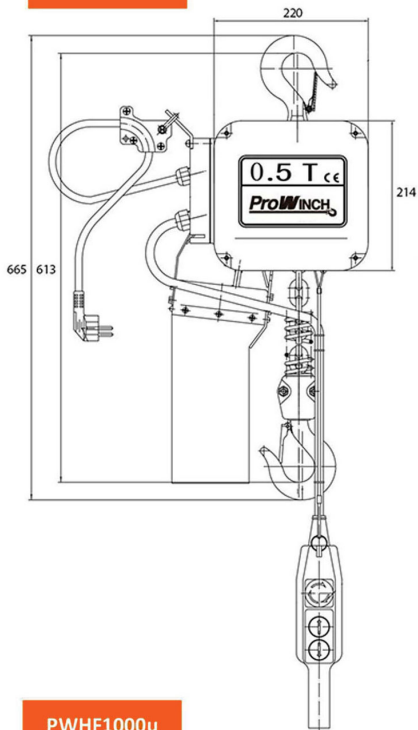

Light die-casting aluminium housing.
 Electromagnetic Safe Brake holds load with no power.
 Upper and lower limit switches prevent over-travel
 14ft Pendant Control with Emergency Stop switch
 Overload Protection
 Forged 360° swivel hook

PWHF1000u

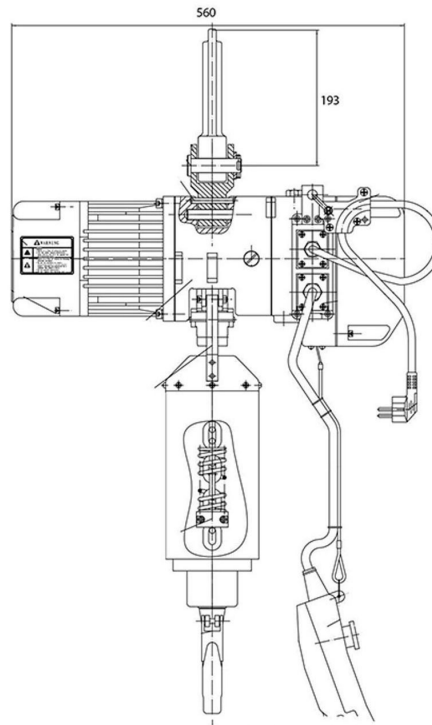
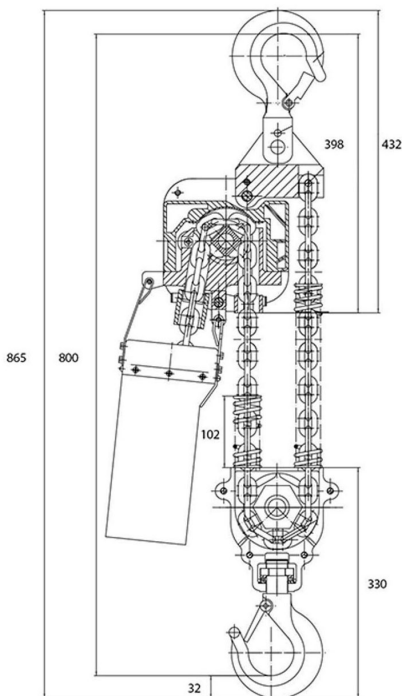

Carcasa de aluminio fundido a presión.
 Freno de Seguridad Electromagnético que sostiene la carga sin energía. Interruptores de límite Superior e Inferior para prevenir sobrecarrera.
 Botonera de control con 4 metros e interruptor de parada de emergencia.
 Protección de sobre carga.
 Gancho Forjado de giro libre 360

Unit Weight & Dimensions

H Minimum Headroom	31 in / 800 mm
D Depth	300 mm
A Total Height	865 mm
W Width	22 in / 560 mm
Total Unit Weight	171 lbs / 78 Kg

Packaging Weight & Dimensions

Package 1 Net Weight	171 lbs / 78 Kg
Package 1 Width	14 in / 35.56 cm
Package 1 Gross Weight	171 lbs / 78 Kg
Package 1 Height	22 in / 55.88 cm
Package 1 Length	32 in / 81.28 cm