



1/2 ton 1100 lb 220V 1 Speed Electric Chain Hoist Power Trolley 20 ft. G80 Chain H2 Duty

Key features

- Load Capacity: 1/2 ton (1100 lbs), designed for moderate lifting applications.
- Voltage: 220V, compatible with standard industrial power supplies.
- Operation Speed: 1 speed, for consistent and reliable performance.
- 3 Year Warranty, Customer Support and Service in the USA

Electric Chain Hoist Description

This electric chain hoist provides a 1/2 ton (1100 lb) lifting capacity and operates on 220V power. It comes with a power trolley for smooth and controlled horizontal movement and features a 20 ft G80 chain for reliable strength. With a single-speed motor and an H2 duty rating, this hoist is designed for efficient performance in heavy-duty applications, offering dependable lifting capabilities for industrial use.

Prowinch Electric Chain Hoist

All of our **Electric Chain Hoists** are created with the goal of offering the best price-performance ratio. Key components such as lifespan factors are constantly tested and improved in order to offer the best product for the price.

Key Components

All internal components have been upgraded to meet the highest quality standards. Key electronic components are produced by American or German brands, and we use American-made lubricants to ensure the lifespan of gears and reducers. Final assembly and all tests are performed in the US before shipping to ensure that every unit meets the corresponding standard.

Duty Classification

Duty classification is a key factor when choosing the right chain hoist. These H2 hoists are suitable for light machine shop fabricating, service, and maintenance. For uniformly distributed work periods, the hoists have 12.5% max. operational time per hour and can handle up to 75 starts per hour. When being used for infrequent work periods, the hoist can be operated for 15 minutes from a cold start with up to 100 starts per hour. Operational time ratings are calculated at a 65% load factor, as per ASME HST-1-2012.

Control System

This electric chain hoist comes standard with a pendant control. The length of the control is 4 feet less than the lifting height, which allows it to be easily operated from ground-level. An optional wireless control is available for extra convenience.

Braking System

The **electromagnetic brake system** is tested at 125% of the hoist capacity and is designed to automatically engage immediately upon any loss of power.

Technical Specifications

Rated Load Capacity	1100 lb / 500 kg	Emergency Stop	Yes
Standard Lifting Height	20 ft / 6 m	Contactora	TECO 12 AMP
Speed (f/m) / min	16 ft / 5 m	Load Chain Type	G80
Number of Speeds	1 Speed	Load Chain Size	8x24 mm
Capacity Range	1	Chain Falls	1
Voltage	1 Phase 220~240V 50/60Hz	Chain Length	20 ft / 6 m
USA and Canada Voltage	220~240V 1Φ	Humidity	<85%
Available Voltages	230V 1Φ	Temperature	-4 ~ 104° F / -20 ~ 40° C
Duty Class	H2/M3/1Bm/Class B	Trolley Power	0.45 kW
Motor/Engine Power	0.65 kW	Noise Level	70 dB
Motor AMP	4	Trolley Speed /min	70 ft / 21 m
Motor Brake	Yes	Trolley Number of Speeds	1
Insulation Grade	F	I-Beam Width Range	2~6 in
IEC Motor Protection	IP54	Minimum Turn Radius	8.6 ft / 2.62 m
Control	Pendant Control and Optional Wireless	Standards Compliance	ASME HST-1 , ASME B30.16 , B30.17 , EN14492-2 , EN60204-32
Control Voltage	24V	Warranty	3 Year

PWHC500i

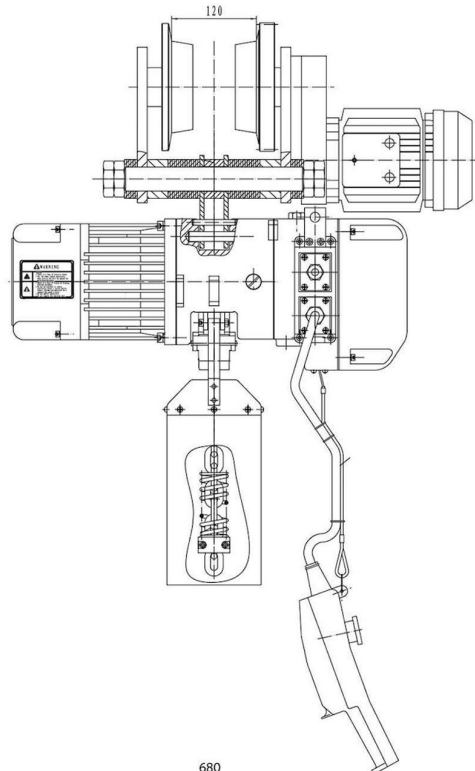
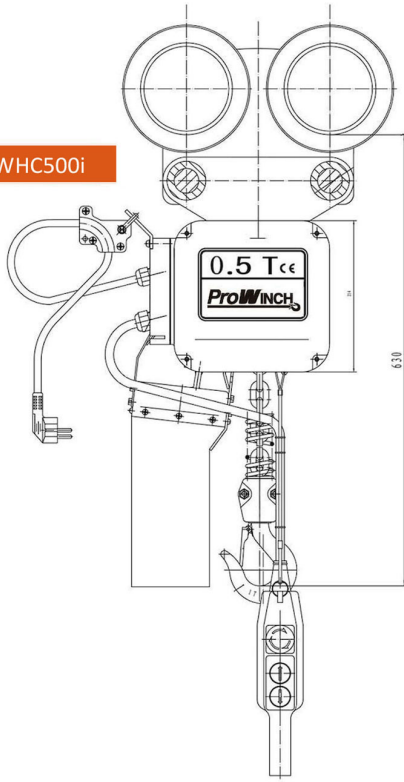

Carcasa de aluminio ligera fundida a presión.
 El freno electromagnético mantiene la carga sin energía.
 Los interruptores de límite superior e inferior previenen el sobrevuelo
 14 pies de suspensión con interruptor de parada de emergencia
 Protección de sobrecarga
 Gancho giratorio forjado de 360°

PWHC1000i

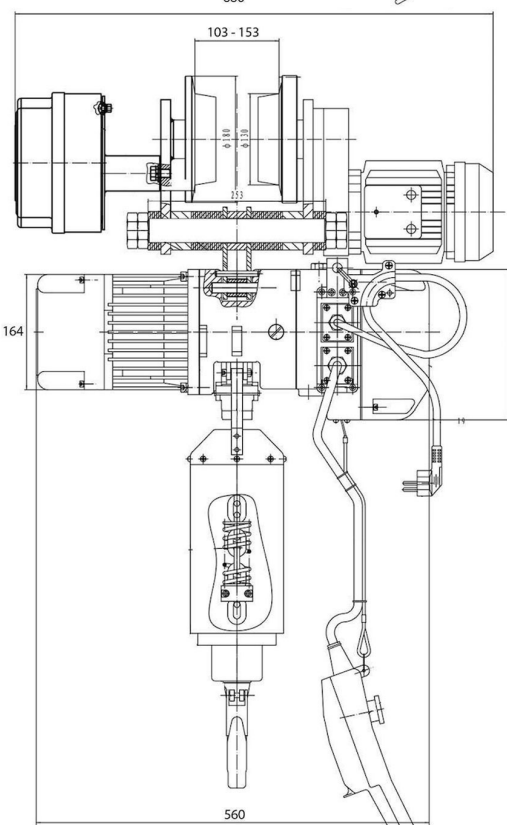
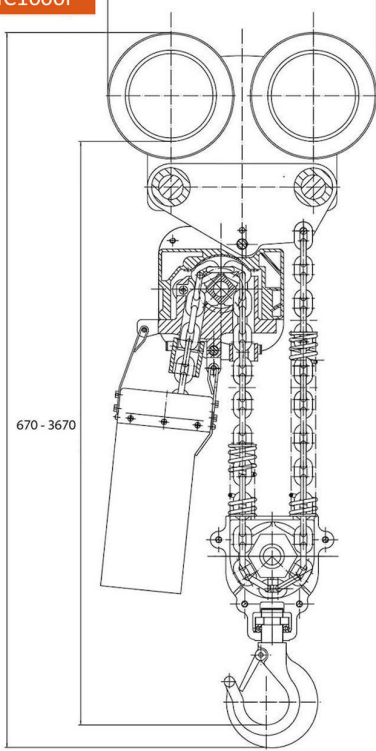

Light die-casting aluminium housing.
 Electromagnetic Safe Brake holds load with no power.
 Upper and lower limit switches prevent over-travel
 14ft Pendant Control with Emergency Stop switch
 Overload Protection
 Forged 360° swivel hook

855 - 3855

670 - 3670

164

214

560

Referential Images
 Specifications may change without notice

Unit Weight & Dimensions

H Minimum Headroom	25 in / 630 mm
Total Unit Weight	234 lbs / 107 Kg

Packaging Weight & Dimensions

Package 1 Net Weight	234 lbs / 106 Kg
Package 1 Width	27 in / 68.58 cm
Package 1 Gross Weight	264 lbs / 120 Kg
Package 1 Height	29 in / 73.66 cm
Package 1 Length	21 in / 53.34 cm