



1/2 Ton Lever Hoist 10 ft. G100 Chain

Key features

- ISO 16872 Zinc-Plated G100 Load Chain with Overload Protection
- Reinforced Gear Cover, Zinc Plated Chain Guide and Side Plates
- CE Certified by TUV Rheinland
- Reliable and Stable Double Pawl Brake System, Tested at 125% of Load Capacity
- 3 Year Warranty, Customer Support and Service in the USA

Lever Chain Hoist Description

The **Prowinch 1/2 ton Lever Chain Hoist** allows you to easily and safely lift loads up to 10 feet. It is perfect for warehouses, auto shops, and garages. The hoist is lightweight and portable, and the durable hook allows the hoist to be quickly mounted wherever it is needed.

Prowinch Lever Chain Hoist

All of our **Lever Chain Hoists** are created with the goal of offering the best price-performance ratio. Key components such as lifespan factors are constantly tested and improved in order to offer the best product for the price.

Braking System

The reliable double pawl brake system is tested at 125% of the hoist capacity.

Technical Specifications

Rated Load Capacity	1120 lb / 0.5 t	Load Chain Size	Ø5 mm
Standard Lifting Height	10 ft / 3 m	Chain Falls	1
Capacity Range	1	Standards Compliance	ANSI/ASME B30.21, EN13157, ISO 16877-2008
Lever Force	68 lbs / 31 kg	Warranty	3 Year
Load Chain Type	G100		

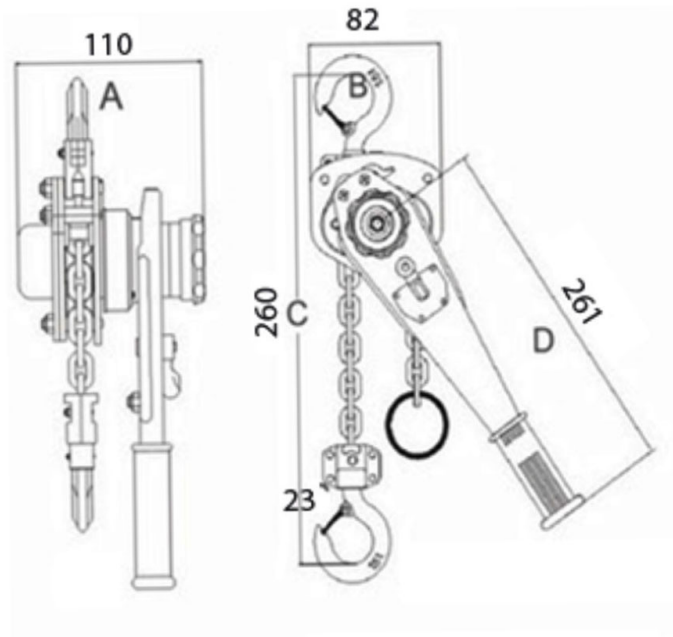

Dimensions in mm /
Dimensiones en mm

Unit Weight & Dimensions

Total Unit Weight	8 lbs / 4 Kg
--------------------------	--------------

Packaging Weight & Dimensions

Package 1 Net Weight	8 lbs / 4 Kg
Package 1 Width	4 in / 10.16 cm
Package 1 Gross Weight	11 lbs / 5 Kg
Package 1 Height	14 in / 35.56 cm
Package 1 Length	4 in / 10.16 cm