

3000 kg Push Trolley Ex spark resistant series 3 t capacity



Key features

- Capacity: Supports loads up to 3 tons (3000 kg), perfect for heavy material handling tasks.
- Spark Resistant Design: Specifically engineered to minimize spark generation, ensuring safety in explosive settings.
- Push Mechanism: Ergonomic design facilitates easy maneuvering, enhancing operational efficiency.
- 3 Year Warranty, Customer Support and Service in the USA

Explosion Proof Description

The 3000 kg Push Trolley from the Ex Spark Resistant Series is expertly engineered for safe and efficient material handling in hazardous environments. With a substantial capacity of 3 tons (3000 kg), this trolley is ideal for use in explosive atmospheres, ensuring compliance with rigorous safety standards while providing reliable performance.

Technical Specifications

Rated Load Capacity	3.15 ton / 6944 lbs	Minimum Turn Radius	1.7m [5.58 ft]
Load Test	150% [Rated Load / Capacidad Nominal]	Standards Compliance	ASME B30.17 / ATEX Directive
Explosion Proof Protection	Ex II 2 GD c II B T105 °C	Made in	Japan
Control	Manual Push	Warranty	3 Year
I-Beam Width Range	89 - 157.5 mm [3.5 - 6.2 in]		

Capacity / Capacidad	A	B	C	D	E	F	H	I	J	K
1102 lb / 0.5 t	7.50 in / 191 mm	5.0 in / 127 mm	2.9 in / 74 mm	6.1 in / 155 mm	2.7 in / 69 mm	3.9 in / 99 mm	4.2 in / 107 mm	1.3 in / 33 mm	1.1 in / 33 mm	3.9 in / 99 mm
2204 lb / 1 t	8.70 in / 221 mm	5.0 in / 127 mm	2.9 in / 74 mm	6.7 in / 170 mm	3.1 in / 79 mm	4.5 in / 114 mm	4.4 in / 112 mm	1.2 in / 30 mm	1.1 in / 28 mm	4.0 in / 102 mm
3527 lb / 1.5 t	10.2 in / 262 mm	5.6 in / 142 mm	3.7 in / 94 mm	8.1 in / 206 mm	3.8 in / 97 mm	5.3 in / 135 mm	5.9 in / 150 mm	2.0 in / 51 mm	1.5 in / 38 mm	5.5 in / 140 mm
4409 lb / 2 t	10.2 in / 260 mm	5.6 in / 142 mm	3.7 in / 94 mm	8.1 in / 206 mm	3.8 in / 97 mm	5.3 in / 135 mm	5.9 in / 150 mm	2.1 in / 53 mm	1.5 in / 38 mm	5.5 in / 140 mm
6944 lb / 3 t	11.3 in / 287 mm	5.7 in / 145 mm	3.8 in / 97 mm	9.4 in / 239 mm	4.5 in / 114 mm	5.9 in / 150 mm	7.1 in / 180 mm	2.5 in / 64 mm	1.9 in / 48 mm	6.6 in / 168 mm
11023 lb / 5 t	12.9 in / 328 mm	6.5 in / 165 mm	4.9 in / 124 mm	11.4 in / 290 mm	4.9 in / 124 mm	6.6 in / 167 mm	8.7 in / 221 mm	2.9 in / 74 mm	2.3 in / 58 mm	8.2 in / 208 mm
17636 lb / 8 t	17.0 in / 432 mm	6.5 in / 165 mm	7.0 in / 178 mm	13.0 in / 330 mm	6.2 in / 157 mm	8.6 in / 218 mm	9.6 in / 243 mm	3.9 in / 99 mm	3.1 in / 79 mm	9.1 in / 231 mm
22046 lb / 10 t	17.0 in / 432 mm	7 in / 178 mm		13.0 in / 330 mm	6.2 in / 157 mm	8.6 in / 218 mm	9.6 in / 243 mm	3.9 in / 99 mm	3.1 in / 79 mm	9.1 in / 231 mm
33069 lb / 15 t	22.8 in / 579 mm	9 in / 229 mm		18.2 in / 462 mm	7.7 in / 196 mm	11.6 in / 295 mm	10.7 in / 272 mm	3.3 in / 84 mm	3.7 in / 94 mm	9.7 in / 246 mm
44092 lb / 20 t	22.8 in / 579 mm	9 in / 229 mm		18.2 in / 462 mm	7.7 in / 196 mm	11.6 in / 295 mm	10.7 in / 272 mm	3.3 in / 84 mm	3.7 in / 94 mm	9.7 in / 246 mm

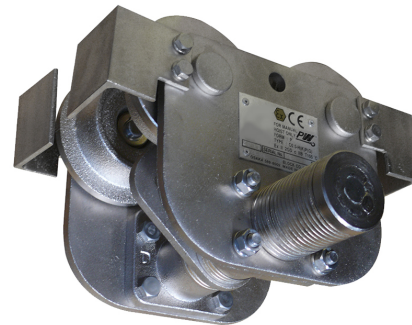
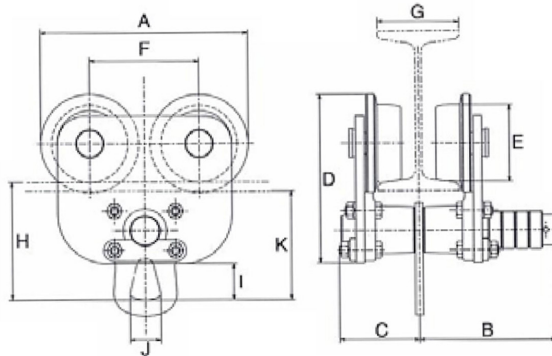

Referential Images
Specifications may change without notice

Unit Weight & Dimensions

H Minimum Headroom	521 mm [20.5 in] Combined Hoist Trolley	Package 1 Net Weight	60 lbs / 27 Kg
X Wheels Diameter	114.3 mm [4.5 in]		
Total Unit Weight	60 lbs / 28 Kg		

Packaging Weight & Dimensions