



Hydraulic Power Pack 190 Bar / 19 Mpa / 98LxM / 400 L.

Key features

- High Pressure: Operates at 190 Bar (19 MPa), providing substantial hydraulic pressure for powerful applications.
- Flow Rate: Delivers a flow rate of 98 liters per minute (LxM), ensuring efficient and effective hydraulic performance.
- Tank Capacity: Features a 400-liter hydraulic oil tank, allowing for extended operational periods without frequent refills.
- 3 Year Warranty, Customer Support and Service in the USA

Hydraulic Power Pack 190 Bar / 19 Mpa / 98LxM / 400 L Description

This powerful hydraulic power pack operates at 190 Bar (19 Mpa) and delivers a flow rate of 98 liters per minute, with a 400-liter tank capacity. Built for heavy-duty industrial and construction applications, it provides reliable and efficient hydraulic pressure and flow for demanding tasks, ensuring optimal performance and durability in tough environments.

Technical Specifications

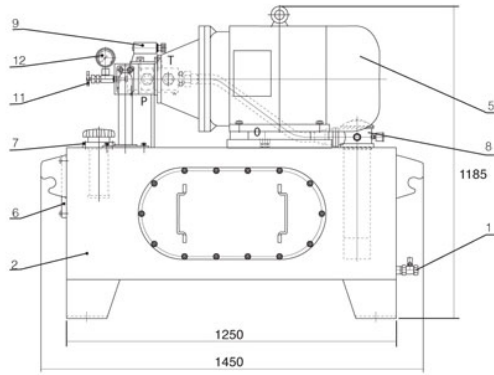

Dimensiones in mm / Dimensiones en mm

