



## 300kg Manual Jibcrane - Custom Dimension up to 2m x 2m

### Key features

- Load Capacity: Supports up to 300 kg for various lifting tasks.
- Durable Construction: Built with high-quality materials for stability and longevity.
- Custom Dimensions: Adjustable up to 2m x 2m to suit specific workspace requirements.
- 3 Year Warranty, Customer Support and Service in the USA

### 300kg Manual Jibcrane Description

The 300 kg Manual Jib Crane is a versatile lifting solution designed to enhance efficiency in material handling tasks. With customizable dimensions of up to 2m x 2m, this jib crane can be tailored to fit various workspaces and applications. Its robust construction allows for a load capacity of 300 kg, making it ideal for workshops, factories, and assembly lines.

## Technical Specifications

Warranty 3 Year

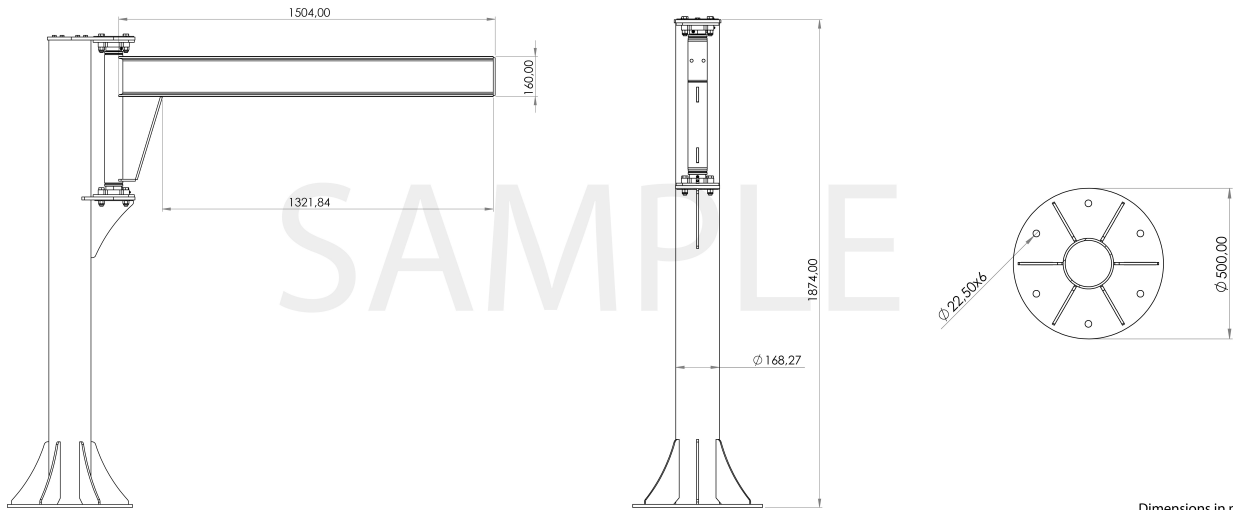

Dimensions in mm / Dimensiones en mm