



550 lb 220V Portable Electric Rope Hoist 60 meters lifting height H1 Duty

Key features

- Load Capacity: 550 lbs (250 kg), suitable for lighter lifting tasks.
- Voltage: 220V, compatible with standard industrial electrical systems.
- Lifting Height: 60 meters (197 feet), providing substantial vertical reach for a wide range of applications.
- 1 Year Warranty, Customer Support and Service in the USA

Electric Wire Rope Hoist Description

250 kg Wireless Electric Wire Rope Hoists are used for raising and lowering material. Power Cord is standard at 3 ft. for Hook and Push Trolley Mounts. Hoists usually ship within 1-3 business days after ordering. Please call us at 1 (800) 971-8061 for any special requests. The Highest Quality, most Technologically Advanced Hoist in the Industry. Our hoist ranges from basic Light Duty H1 to Heavy Duty Motor - 60 minute, H4 classification, Class B insulation with cooling fins and standard thermal motor protection. Compact lightweight body offers one of the lowest headroom hoists in the industry. Extremely durable and reliable Pull Rotor Motor Brake. Contains NO brake coil to fail like conventional disc brakes. Easy Maintenance Control Panel is hinged to swing out to provide fast, easy, and trouble-free access. Completely Sealed Body suitable for both indoor and outdoor applications, including harsh environments. Gaskets throughout the hoist provide an IP54 rating. Oil Bath and precision machined helical and spur gears provide for quiet, smooth, and cool operations.

Technical Specifications

Rated Load Capacity	551 lb / 250 kg	Insulation Grade	B
Standard Lifting Height	200 ft / 60 m	IEC Motor Protection	IP54
Speed (f/m) / min	49 ft / 15 m	Control	Pendant Control and Optional Wireless F21
Number of Speeds	1 Speed	Emergency Stop	YES
Voltage	1 Phase 220~240V 50/60Hz	Wire Rope	ø3/16 in ø4.5 mm
Duty Class	H1/M2/1Cm/Class A	Humidity	<85%
Motor Type (68)	Squirrel Cage Induction Motor	Temperature	-4°~104° F / -20°~40° C
Motor Power (6)	1300 W	Noise Level	71 dB
Motor Brake	YES	Warranty	1 Year

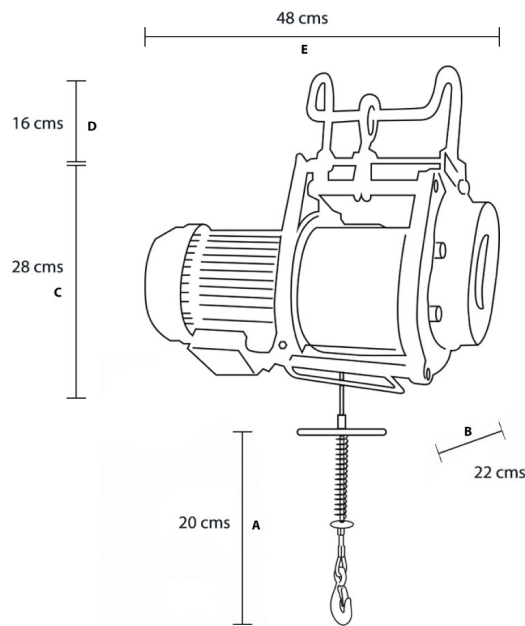

MODEL	PWBH250A
A	20 cm
B	22 cm
C	28 cm
D	16 cm
E	48 cm

Unit Weight & Dimensions

D Depth	9 in / 230 mm
W Width	19 in / 483 mm
Total Unit Weight	68 lbs / 31 Kg

Packaging Weight & Dimensions

Package 1 Net Weight	68 lbs / 31 Kg
Package 1 Width	12 in / 30.48 cm
Package 1 Gross Weight	70 lbs / 32 Kg

Package 1 Height 15 in / 38.1 cm

Package 1 Length 21 in / 53.34 cm