



660 lb 220V 1 Speed Mini Electric Chain Hoist 9 ft. Chain S3 H1 Duty Wireless

Key features

- Load Capacity: Capable of lifting 660 lbs, ideal for light-duty applications.
- Voltage: Operates on 220V, suitable for higher voltage power systems.
- 1-Speed Operation: Single-speed motor for consistent and controlled lifting.
- 1 Year Warranty, Customer Support and Service in the USA

Electric Chain Hoist Description

660 lb Wireless Electric Chain Hoists are used for raising and lowering material. Power Cord is standard at 3 ft. for Hook and Push Trolley Mounts. Hoists usually ship within 1-3 business days after ordering. Please call us at 1 (800) 971-8061 for any special requests. The Highest Quality, most Technologically Advanced Hoist in the Industry. Our hoist ranges from basic Light Duty H1 to Heavy Duty Motor - 60 minute, H4 classification, Class B insulation with cooling fins and standard thermal motor protection. Compact lightweight body offers one of the lowest headroom hoists in the industry. Extremely durable and reliable Pull Rotor Motor Brake. Contains NO brake coil to fail like conventional disc brakes. Easy Maintenance Control Panel is hinged to swing out to provide fast, easy, and trouble-free access. Completely Sealed Body suitable for both indoor and outdoor applications, including harsh environments. Gaskets throughout the hoist provide an IP55 rating. Oil Bath and precision machined helical and spur gears provide for quiet, smooth, and cool operations. Superior Quality Chain is precision gauged, Grade 80, manganese alloy load chain that is heat treated for wear resistance and extended life.

Technical Specifications

Rated Load Capacity	660 lb / 300 kg	Control	Wireless F21 / Optional Pendant Control
Standard Lifting Height	10 ft / 3 m	Control Voltage	2 X AA Battery
Speed (f/m) / min	10 ft / 3 m	Emergency Stop	Yes
Number of Speeds	1 Speed	Contactors	HSIN DA 20 AMP
Voltage	1 Phase 220~240V 50/60Hz	Gear Ratio	119:1
Available Voltages	230V 1Φ	Load Chain Type	G80
FCC ID	OFNF21	Load Chain Size	13/64 in 5.0 mm
Duty Class	H1/M2/1Cm/Class A	Chain Falls	1
Motor Power (6)	410 Watts	Chain Length	10 ft / 3 m
Motor AMP	2.09	Humidity	<85%
Motor Brake	Yes	Temperature	-4 ~ 104° F / -20 ~ 40° C
Insulation Grade	B	Noise Level	80 dB
IEC Motor Protection	IP54	Warranty	1 Year

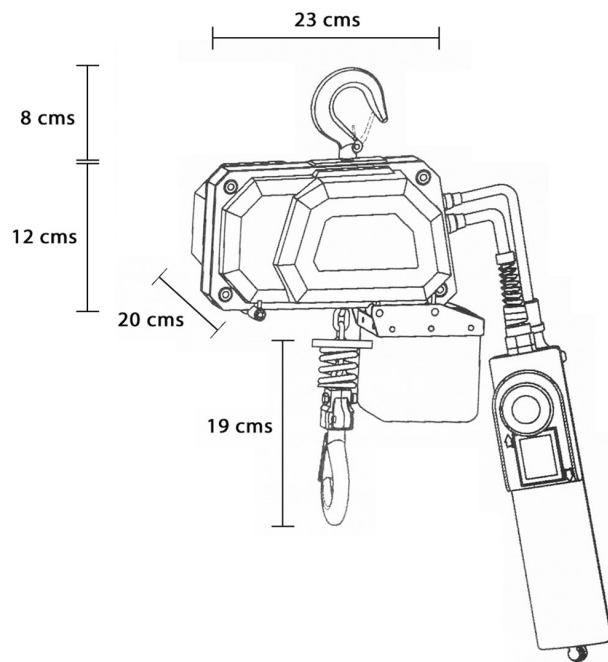
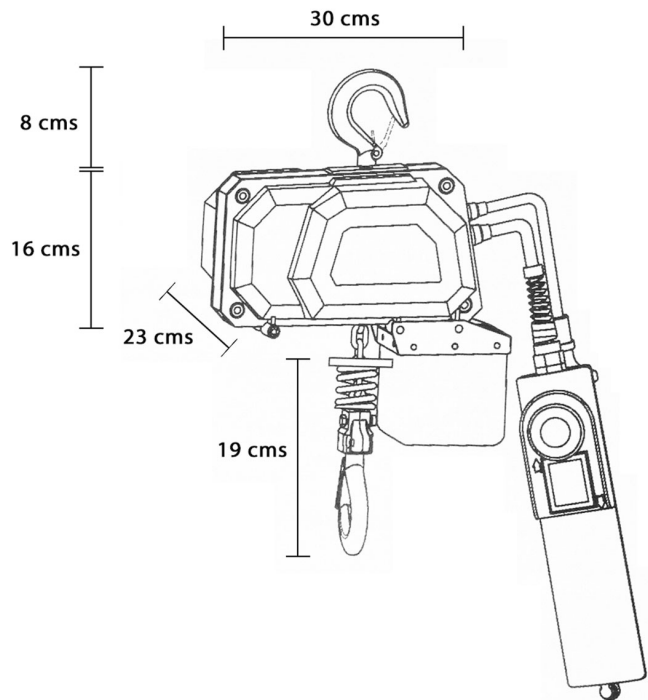

Referential Images
Specifications may change without notice

Unit Weight & Dimensions

Total Unit Weight	30 lbs / 14 Kg
--------------------------	----------------

Packaging Weight & Dimensions

Package 1 Net Weight	30 lbs / 14 Kg
-----------------------------	----------------

Package 1 Width	5 in / 12.7 cm
------------------------	----------------

Package 1 Gross Weight	35 lbs / 16 Kg
-------------------------------	----------------

Package 1 Height	5 in / 12.7 cm
-------------------------	----------------

Package 1 Length	12 in / 30.48 cm
-------------------------	------------------