



## 330 lb 220V 1 Speed Mini Electric Chain Hoist 9 ft. Chain S3 H1 Duty Wireless

### Key features

- Load Capacity: Capable of lifting 330 lbs, suitable for light lifting tasks.
- Voltage: Operates on 220V, ideal for high-efficiency power usage.
- Speed: Features a single-speed motor for steady and reliable lifting.
- 1 Year Warranty, Customer Support and Service in the USA

### Electric Chain Hoist Description

This 330 lb capacity mini electric chain hoist operates on 220V with a single-speed motor. Featuring a 9 ft chain, it is rated for S3 H1 duty, making it ideal for light-duty, intermittent use in industrial or workshop settings. The wireless control enhances ease of operation, providing convenience and flexibility for lifting tasks in tight or elevated spaces. Durable and compact, this hoist is perfect for smaller lifting applications.

## Technical Specifications

<b>Rated Load Capacity</b>	330 lb / 150 kg	<b>Control</b>	Wireless F21 / Optional Pendant Control
<b>Standard Lifting Height</b>	10 ft / 3 m	<b>Control Voltage</b>	2 X AA Battery
<b>Speed (f/m) / min</b>	7.5 ft / 2.3 m	<b>Emergency Stop</b>	Yes
<b>Number of Speeds</b>	1 Speed	<b>Contactors</b>	HSIN DA 20 AMP
<b>Voltage</b>	1 Phase 220~240V 50/60Hz	<b>Gear Ratio</b>	124:1
<b>Available Voltages</b>	230V 1Φ	<b>Load Chain Type</b>	G80
<b>FCC ID</b>	OFNF21	<b>Load Chain Size</b>	5/32 in   4.0 mm
<b>Duty Class</b>	H1/M2/1Cm/Class A	<b>Chain Falls</b>	1
<b>Motor Power (6)</b>	205 Watts	<b>Chain Length</b>	10 ft / 3 m
<b>Motor AMP</b>	1.05	<b>Humidity</b>	<85%
<b>Motor Brake</b>	Yes	<b>Temperature</b>	-4 ~ 104° F / -20 ~ 40° C
<b>Insulation Grade</b>	B	<b>Noise Level</b>	80 dB
<b>IEC Motor Protection</b>	IP54	<b>Warranty</b>	1 Year

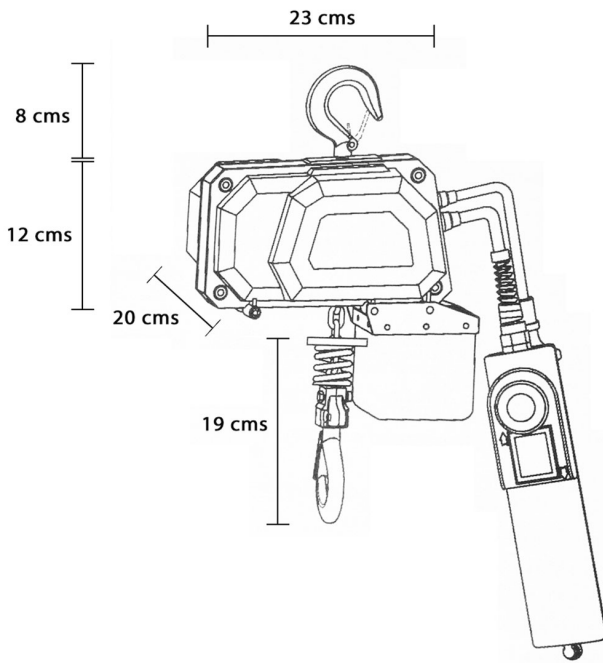
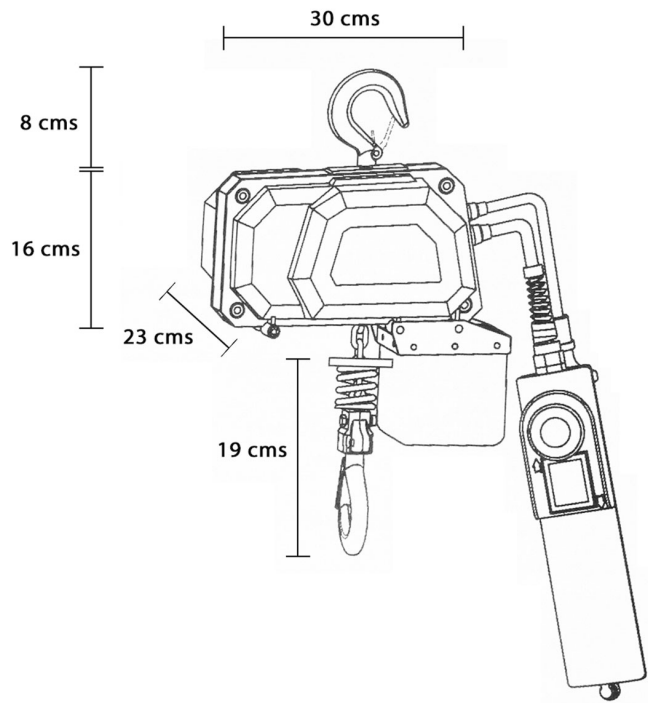

Referential Images  
Specifications may change without notice

## Unit Weight & Dimensions

<b>Total Unit Weight</b>	15 lbs / 7 Kg
--------------------------	---------------

## Packaging Weight & Dimensions

<b>Package 1 Net Weight</b>	15 lbs / 7 Kg
-----------------------------	---------------

<b>Package 1 Width</b>	12 in / 30.48 cm
------------------------	------------------

<b>Package 1 Gross Weight</b>	35 lbs / 16 Kg
-------------------------------	----------------

<b>Package 1 Height</b>	12 in / 30.48 cm
-------------------------	------------------

<b>Package 1 Length</b>	10 in / 25.4 cm
-------------------------	-----------------