



## Manual Gantry Crane 2 Ton 7.8~11.8 ft Height 8 ft Span All Steel Construction

### Key features

- Load Capacity: Supports up to 2 tons for demanding lifting requirements
- Construction: All-steel design for maximum strength and durability.
- Adjustable Height: Height range of 7.8 to 11.8 feet for adaptability in different environments.
- 1 Year Warranty, Customer Support and Service in the USA

### Manual Gantry Crane Description

Introducing the Adjustable Manual Gantry Crane, a versatile lifting solution designed to meet your heavy-duty needs. With a robust construction and a maximum lifting capacity of 2 tons, this crane is built to handle demanding tasks with ease.

One of the key features of this crane is its adjustable height, ranging from 7.8 feet to 11.8 feet. This flexibility allows you to adapt the crane's height to match your specific requirements, ensuring optimal lifting and maneuvering capabilities in various settings.

The crane boasts an impressive 8-foot span, providing ample space for lifting and transporting heavy objects within its reach. Its sturdy all-steel construction guarantees exceptional durability and stability, making it a reliable choice for both indoor and outdoor applications.

Equipped with a manual operation system, this gantry crane allows for precise control during lifting operations. Whether you're working in a workshop, warehouse, construction site, or any other industrial setting, this crane empowers you to handle your loads efficiently and securely.

The Adjustable Manual Gantry Crane is designed with safety in mind. It features robust locking mechanisms to keep the crane securely in place during operation, minimizing the risk of accidents. Additionally, the crane's heavy-duty wheels enable smooth mobility, ensuring easy transportation and positioning wherever you need it.

## Technical Specifications

<b>Warranty</b>	1 Year	<b>Components</b>	This has, Wheels, bolts, pins, knobs, beams and bot pattern plates
<b>Requires Batteries</b>	No		

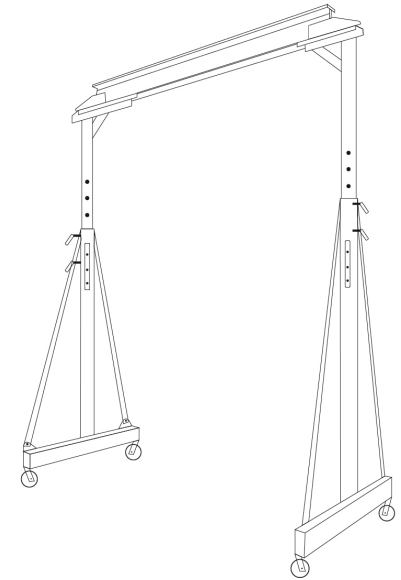
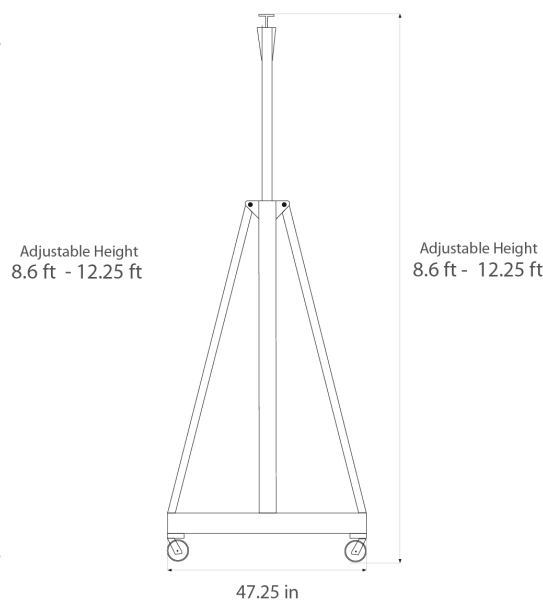
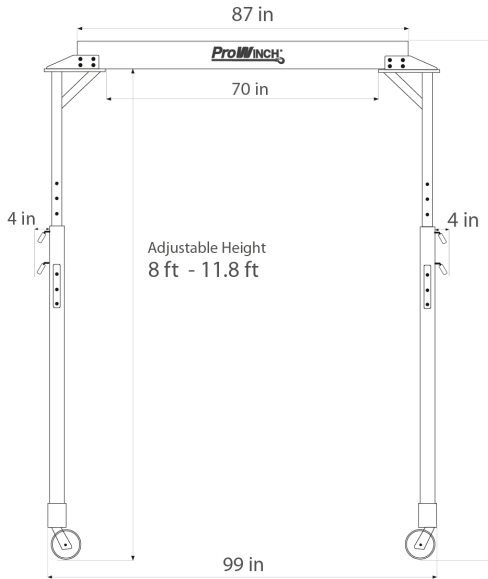

## Unit Weight & Dimensions

**Total Unit Weight** 440 lbs / 200 Kg

## Packaging Weight & Dimensions

**Package 1 Net Weight** 440 lbs / 200 Kg

**Package 1 Width** 19 in / 48.26 cm

**Package 1 Gross Weight** 485 lbs / 220 Kg

**Package 1 Height** 16 in / 40.64 cm

**Package 1 Length** 90 in / 228.6 cm