

440 lb 110V Electric Wire Rope Hoist 38 ft. H1 Duty Wireless

Key features

- Load Capacity: 440 lbs, suitable for lighter lifting tasks.
- Voltage: 110V, compatible with standard electrical outlets.
- Lifting Height: 38 ft, provides ample vertical reach.
- 1 Year Warranty, Customer Support and Service in the USA



Electric Wire Rope Hoist Description

This **Prowinch 440lb Electric Wire Rope Hoist** is one of our most popular units for in-home or light use. This hoist has a compact lightweight body allowing you to conveniently move this hoist from place to place as needed. This product will give you the ability to lift those objects that were holding you back from completing your home projects.

Prowinch Electric Wire Rope Hoists

All of our electric wire rope hoists are created with the goal of offering the best price-performance ratio. Key components such as lifespan factors are constantly tested and improved in order to offer the best product for the price.

Key Components

All internal components have been upgraded to meet the highest quality standards. All testing is performed in the US before shipping to ensure that every unit meets the corresponding standard.

Duty Classification

Duty classification is a key factor when choosing the right unit. This H1 electric wire rope hoist is suitable for infrequent handling, installing and servicing heavy equipment, and idling for long periods between use. For uniformly distributed work periods, the hoist has a 12.5% max. operational time per hour and can handle up to 75 starts per hour. When being used for infrequent work periods, the hoist can be operated for 15 minutes from a cold start with up to 100 starts per hour. Operational time ratings are calculated at a 65% load factor, as per ASME Standards.

Control System

This electric wire rope hoist comes standard with an industrial wireless remote control, which is waterproof, shockproof, and can be operated from 100 feet away. It also features a safety key and emergency stop button.

Braking System

The electromagnetic brake system is tested at 125% of the hoist capacity and is designed to automatically engage immediately upon any loss of power.

Technical Specifications

Rated Load Capacity	440 lb @ 2 lines 220 lb @ 1 line	Insulation Grade	B
Standard Lifting Height	38ft @ 1 line / 19ft @ 2 line	IEC Motor Protection	IP40
Speed (f/m) / min	33 ft/10m @1line 16ft/5m @2line	Control	Wireless F21 Remote Control
Number of Speeds	1 Speed	Control Voltage	2 x AA 1,5v
Voltage	1 Phase 110~120V 60Hz	Emergency Stop	YES
FCC ID	OFNF21	Wire Rope	ø1/8 in ø3 mm
Duty Class	H1/M2/1Cm/Class A	Humidity	<85%
Motor Type (68)	Squirrel Cage Induction Motor	Temperature	-4°~104° F / -20°~40° C
Motor Power (6)	460 W	Noise Level	71 dB
Motor AMP	4.1 AMP	Standards Compliance	Intertek 4006091 , EN 55014-1:2017, EN 55014-2:2015, EN IEC 61000-3-2:2019, EN 61000-3-3:2013
Motor Brake	YES	Warranty	1 Year

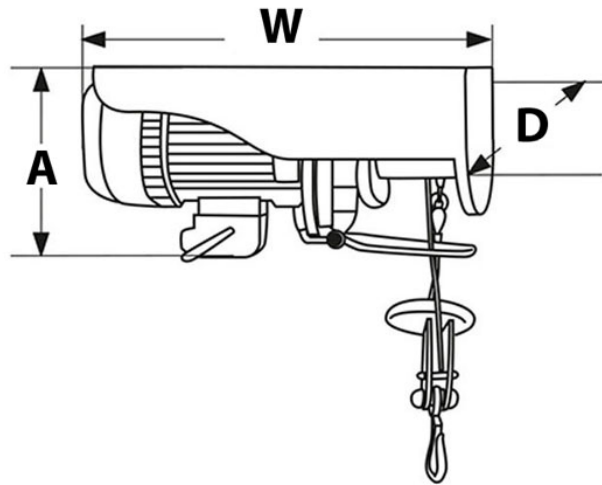

Unit Weight & Dimensions

H Minimum Headroom	10.8 in / 275 mm	Package 1 Net Weight	24 lbs / 11 Kg
W Width	13.0 in / 330 mm	Package 1 Width	8 in / 20.32 cm
D Depth	5.1 in / 130 mm	Package 1 Gross Weight	24 lbs / 11 Kg
Total Unit Weight	24 lbs / 11 Kg	Package 1 Height	11 in / 27.94 cm
		Package 1 Length	16 in / 40.64 cm

Packaging Weight & Dimensions