

440 lb 2200 lb 220V Electric Wire Rope Hoist 38 ft. H1 Duty Wireless

Key features

- Load Capacity: 440 lb (220 kg) or 2200 lb (1000 kg), offering flexibility for different lifting needs.
- Voltage: 220V, suitable for higher voltage power sources.
- Lifting Height: 38 ft, allowing for substantial vertical movement.
- 1 Year Warranty, Customer Support and Service in the USA



Electric Wire Rope Hoist Description

Our 220/240v **Prowinch 200 kg ton Electric Wire Rope Hoist** is the ideal product for light loads and small shop use. Exceeding expectations in performance and durability this is one of the most technologically advanced electric wire rope hoist in the industry. With the convenience of low headroom and a wireless remote this unit can be easily incorporated into your shop or home.

Prowinch Electric Wire Rope Hoists

All of our electric wire rope hoists are created with the goal of offering the best price-performance ratio. Key components such as lifespan factors are constantly tested and improved in order to offer the best product for the price.

Key Components

All internal components have been upgraded to meet the highest quality standards. All testing is performed in the US before shipping to ensure that every unit meets the corresponding standard.

Duty Classification

Duty classification is a key factor when choosing the right unit. This H1 electric wire rope hoist is suitable for infrequent handling, installing and servicing heavy equipment, and idling for long periods between use. For uniformly distributed work periods, the hoist has a 12.5% max. operational time per hour and can handle up to 75 starts per hour. When being used for infrequent work periods, the hoist can be operated for 15 minutes from a cold start with up to 100 starts per hour. Operational time ratings are calculated at a 65% load factor, as per ASME Standards.

Control System

This electric wire rope hoist comes standard with an industrial wireless remote control, which is waterproof, shockproof, and can be operated from 100 feet away. It also features a safety key and emergency stop button.

Braking System

The electromagnetic brake system is tested at 125% of the hoist capacity and is designed to automatically engage immediately upon any loss of power.

Technical Specifications

Rated Load Capacity	200Kg @ 2 lines 100Kg @ 1 line	IEC Motor Protection	IP54
Standard Lifting Height	40ft single line / 20ft double line (12m / 6m)	Control	Wireless F21 Remote Control
Speed (f/m) / min	33 ft/10m @1line 16ft/5m @2line	Control Voltage	2 x AA 1,5v
Number of Speeds	1 Speed	Emergency Stop	YES
Voltage	1 Phase 220~240V 50/60Hz	Wire Rope	ø1/8 in / ø3.0 mm
FCC ID	CTB210313002EX	Humidity	<85%
Duty Class	H1/M2/1Cm/Class A	Temperature	-4°~104° F / -20°~40° C
Motor Type (68)	Squirrel Cage Induction Motor	Noise Level	71 dB
Motor Power (6)	450W	Standards Compliance	Intertek 4006091 , CAN/CSA C22.2 , EN14492-2 , EN60204-32
Motor Brake	YES	Warranty	1 Year
Insulation Grade	B		

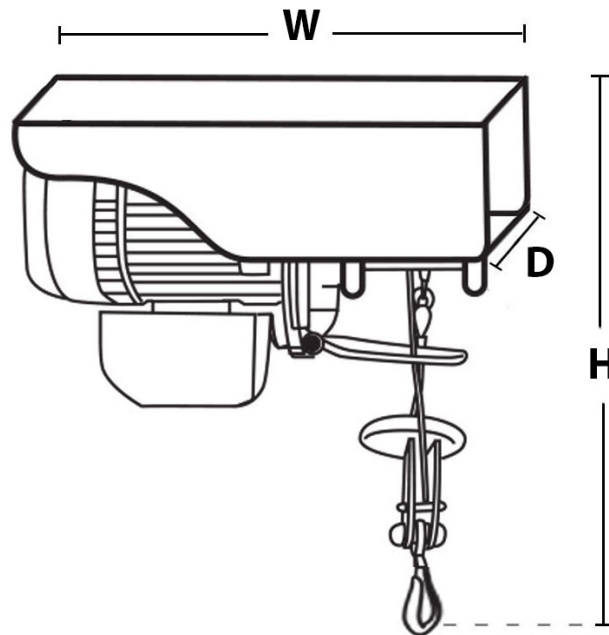

Unit Weight & Dimensions

H Minimum Headroom	308 mm / 12.1 in
W Width	14.3 in / 365 mm
D Depth	5.70 in / 146 mm

Packaging Weight & Dimensions

Package 1 Net Weight	22 lbs / 10 Kg
Package 1 Width	8 in / 20.32 cm
Package 1 Gross Weight	24 lbs / 11 Kg

Total Unit Weight 22 lbs / 10 Kg

Package 1 Height 11 in / 27.94 cm

Package 1 Length 16 in / 40.64 cm